

5G

Mobile Communications for 2020

Simpósio Brasileiro de Telecomunicações 2015
Juiz de Fora - MG

André Barreto
Bruno Faria
Erika Almeida
Rafhael Amorim
Robson Vieira



INDT

Natural Partner for Innovation

Ignacio Rodriguez



**AALBORG
UNIVERSITY**
DENMARK

Presentation Outline

1. 5G Drivers and Vision

1. Scenarios and Challenges
2. Requirements

2. The road to 5G

1. Architecture
 1. LTE Architecture
 2. 5G architecture topics
2. Frame Structure
3. Air Interface and Modulation
4. Interference control
5. Massive MIMO

6. Spectrum and Propagation

7. Millimeter wave communication
8. Visible Light Communication
9. Hardware Implementation

3. Standardization

4G (3GPP-LTE)



- 4G LTE networks are still expanding across global markets
 - In June 2015, 418 commercial LTE networks in 142 countries
 - 67 LTE-A in 39 countries
 - LTE subscriptions reached 635 million at 1Q2015 and will reach 2 billion by the end of 2018
 - Eastern Asia leads the market with 49% LTE subscriptions
 - In March 2015, LTE had 9% market share
 - GSM still has 56% of the world market
 - North America leads in terms of Market Share (44% are LTE users), only 2,6% in Latin America
 - Brazil LTE subscriptions reached 8 million at the end of March 2015
- 4G 3GPP activities still ongoing
 - Rel-12 (Mar2015) recently frozen
 - Rel-13 (Mar 2016) ongoing
 - Several research topics: Enhanced Small Cell for LTE, LTE Multi-Antenna/site technologies like 3D-beamforming, Interworking with WiFi, SON, Advanced receivers, MTC, D2D, etc



So why do we need 5G????

Drivers and Vision

- Why 5G?
 - **Mobile IP traffic** is expected to overtake fixed traffic in 2019, when it will correspond to 66% of the total IP traffic: up to 500 Exabytes by 2020. (1 Exabyte = 1 million terabytes).

Average throughput per month per connected device (mobile networks)

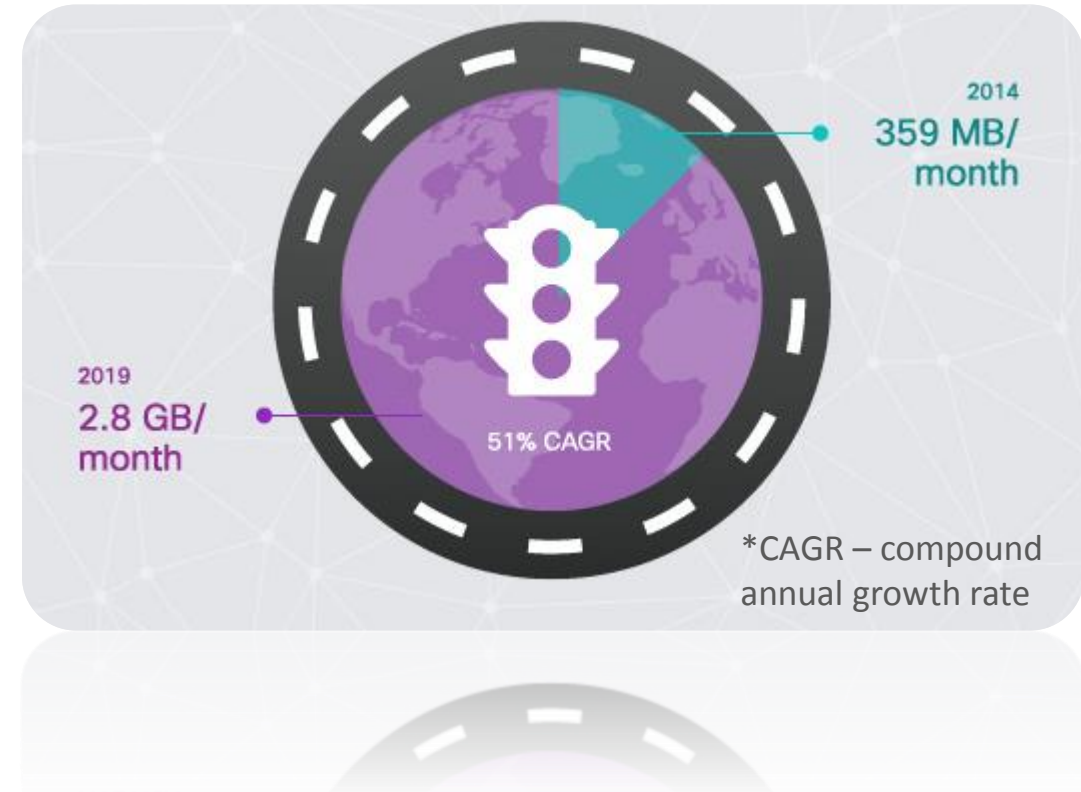

Drivers and Vision

- Why 5G?
 - Number of **mobile users** will increase 4.3% annually, from 2014 to 2019. In 2019, this number is expected to reach 5.2 billion, in contrast to 4.3 billion in 2014.

Number of mobile users: 2014 and 2019

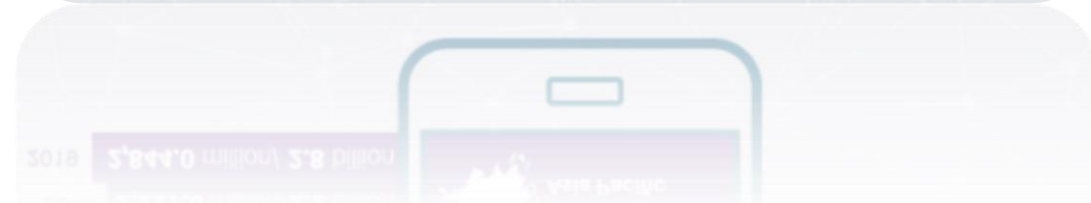
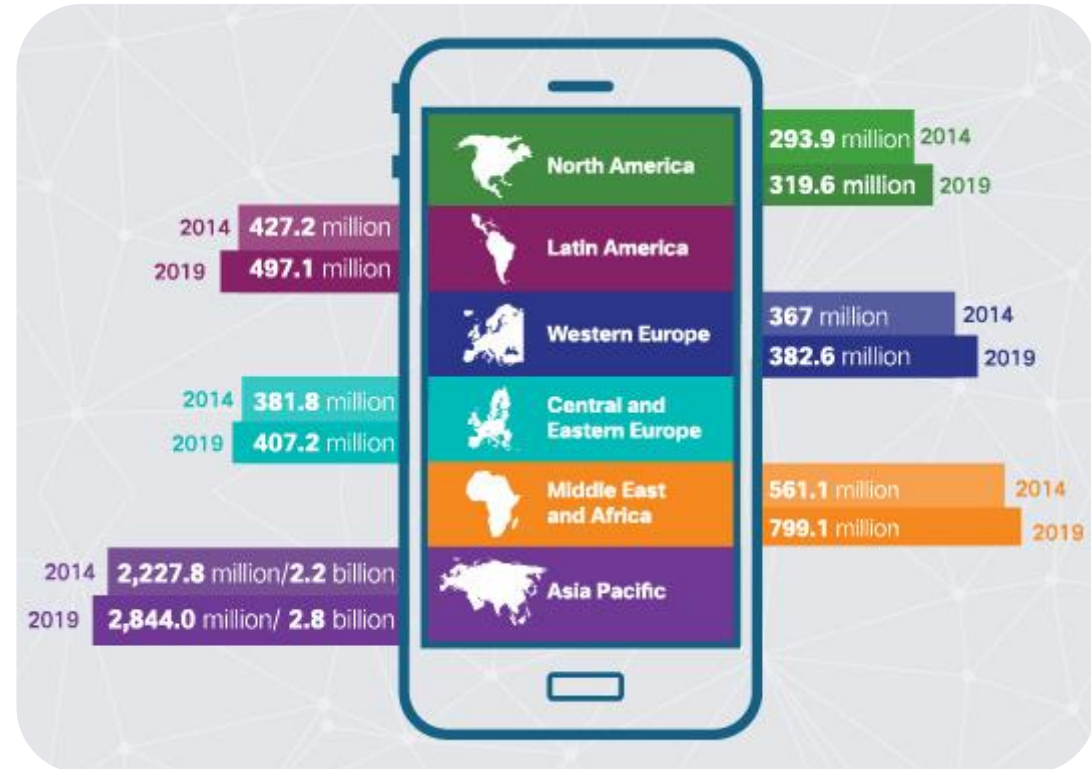

Drivers and Vision

■ Why 5G?

- Number of **connected devices** will surpass the world's population, going up to 11 billion in 2019.
 - North America: 3.1 per capita
 - Latin America: 1.5 per capita
 - Western Europe: 2.8 per capita
 - Central and Eastern Europe: 2.1 per capita
 - Middle East and Africa: 1.1 per capita
 - Asia Pacific: 1.3 per capita

Average throughput per connected device (mobile networks)

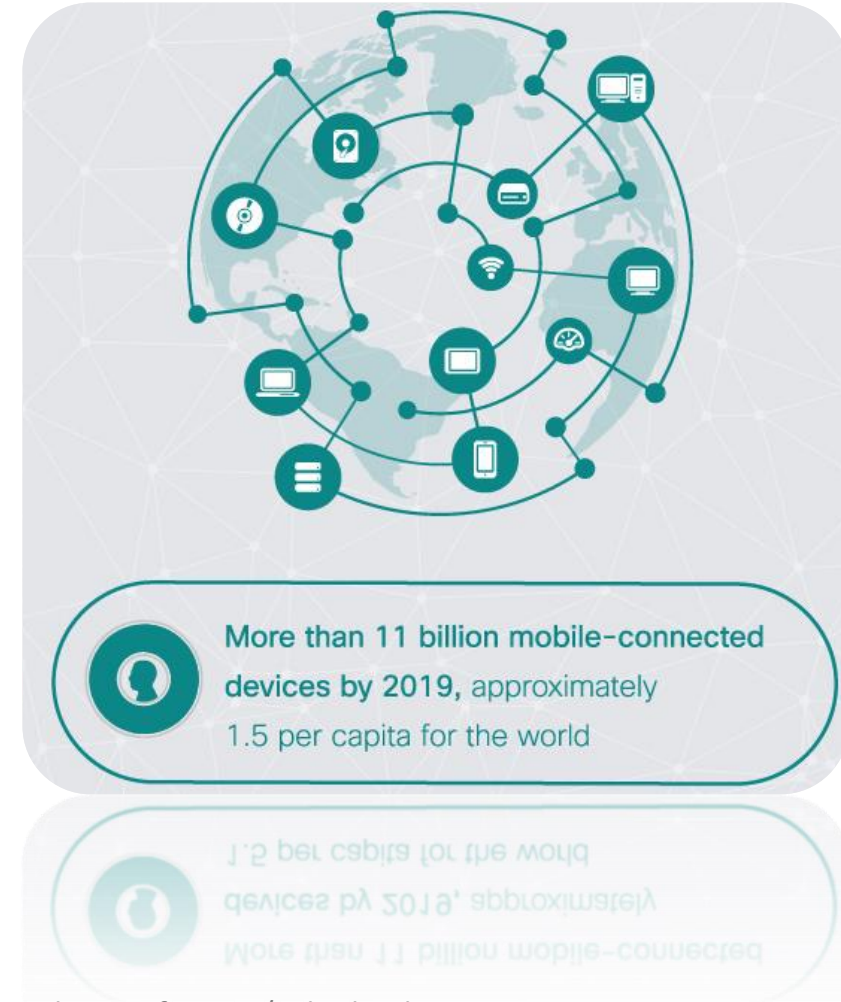

Drivers and Visions

- What is 5G
 - Nobody really knows....
- Different scenarios and visions
 - Industry
 - Research Forums
 - Regulators
 - International Organizations
- But a few common issues
 - Not only an evolved/faster 4G, but
 - **Internet of Things**
 - ✓ Many more terminals
 - ✓ Higher reliability
 - ✓ Lower latency
 - ✓



KEY FORUMS & CONFERENCES



ieeevt.org / vtc2015fall /

Welcome to VTC2015-Fall in Boston!

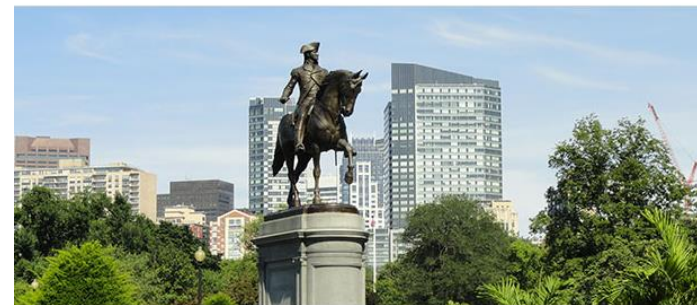

- UPDATE Home
- General Information
- Track Descriptions
- Committees
- Exhibits / Patronage
- Conference Program
- NEW Registration
- NEW Tutorials
- Hotel Information
- For Authors
- NEW Accepted Papers



KEY CONSORTIUMS



5GNOW

IS-WIRELESS acquires funds for research on 5G:

- ✓ Participation in 5GNOW - EU 7FP project
- ✓ Design of new PHYs for systems beyond LTE/LTE-A
- ✓ Leadership in MAC and network interface development



Research Centres



AALBORG UNIVERSITY
DENMARK



Aalto University



Fraunhofer

Heinrich Heine Institute



TECHNISCHE
UNIVERSITÄT
DRESDEN



instituto de
telecomunicações

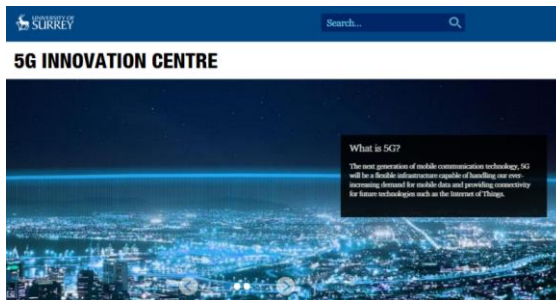

INDUSTRY



Among others....

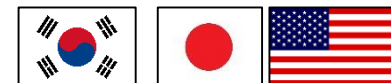

??????



Scenarios and Challenges

■ Why 5G?

- New **communication challenges** and requirements that are not achieved by current technologies:
 - Amazingly fast
 - Great service in a crowd
 - Ubiquitous things communicating
 - Best experience follows you
 - Super real-time and reliable connections

Possible Futures in 2020

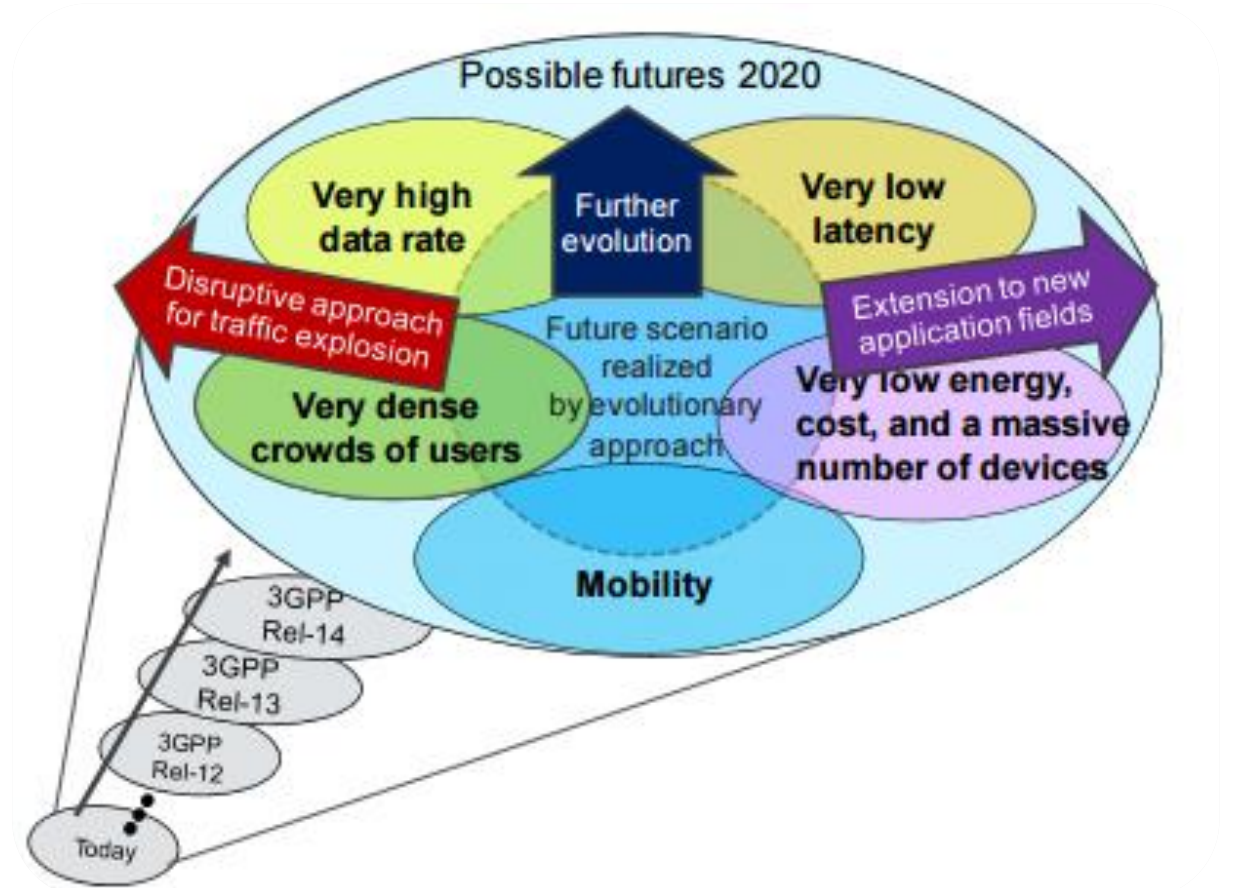

Scenarios and Challenges

- Amazingly fast
 - 5G technology should support **1000 times higher mobile traffic** data volume per area.
 - Provide high data-rates at the application layer. In this scenario, users can enjoy the great experience of instantaneous connection.

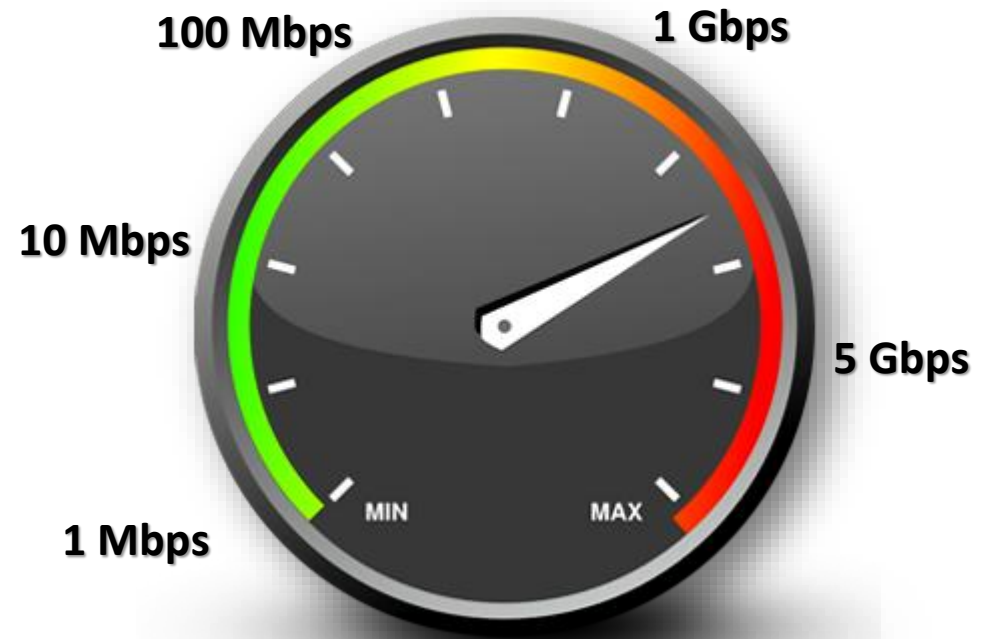

Scenarios and Challenges

Amazingly fast

- In order to realize this, **wider carriers in new spectrum bands** might be needed.
- Many companies foresee the interworking of LTE evolution and new 5G technology, occupying a new spectrum band in the millimeter and centimeter wave bands.

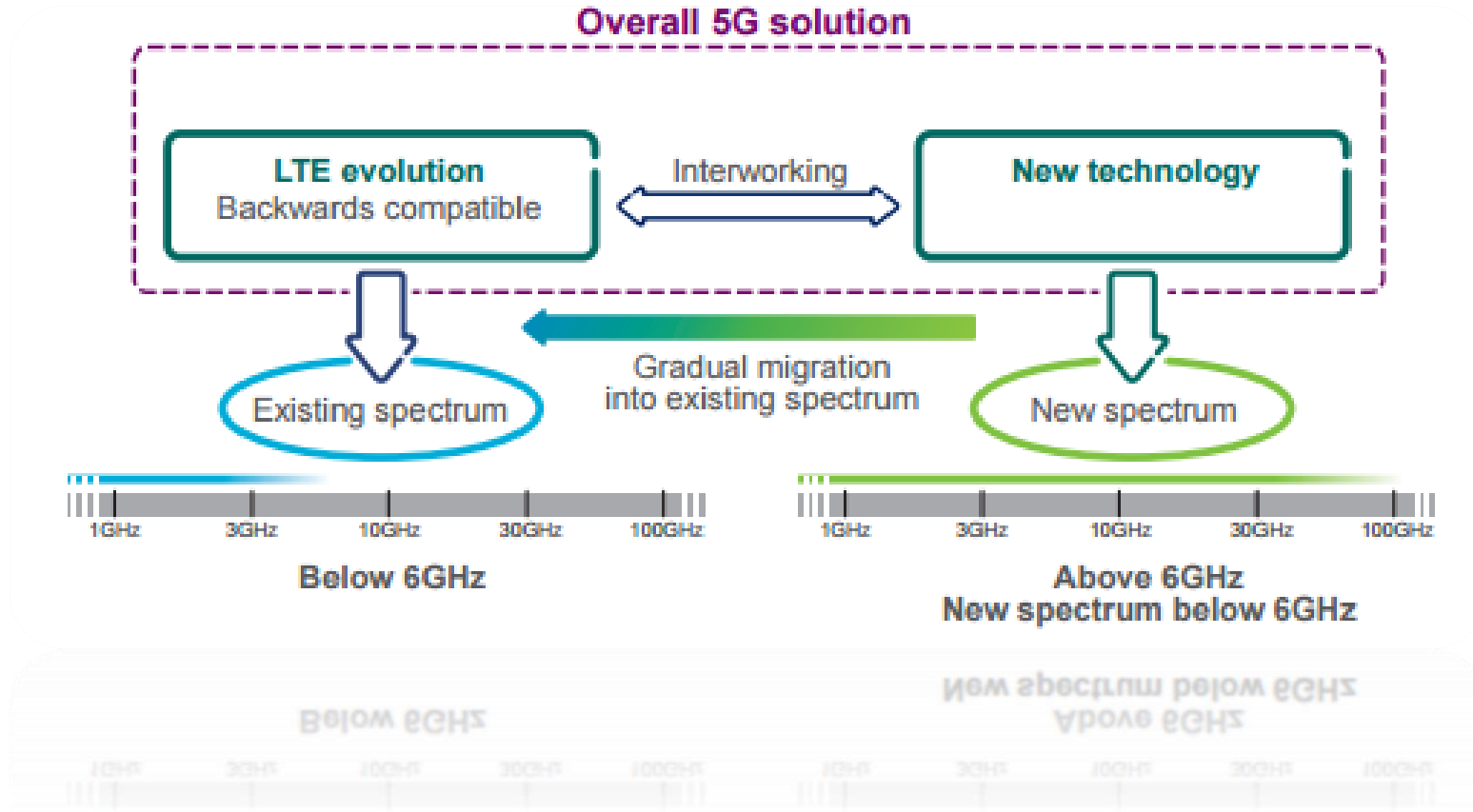

<http://www.ericsson.com/res/docs/whitepapers/wp-5g.pdf>

Scenarios and Challenges

- Amazingly fast
 - 5G will be a heterogeneous deployment, where the total capacity will be the sum of capacity of macro cells, small cells and ultra-dense small cells.

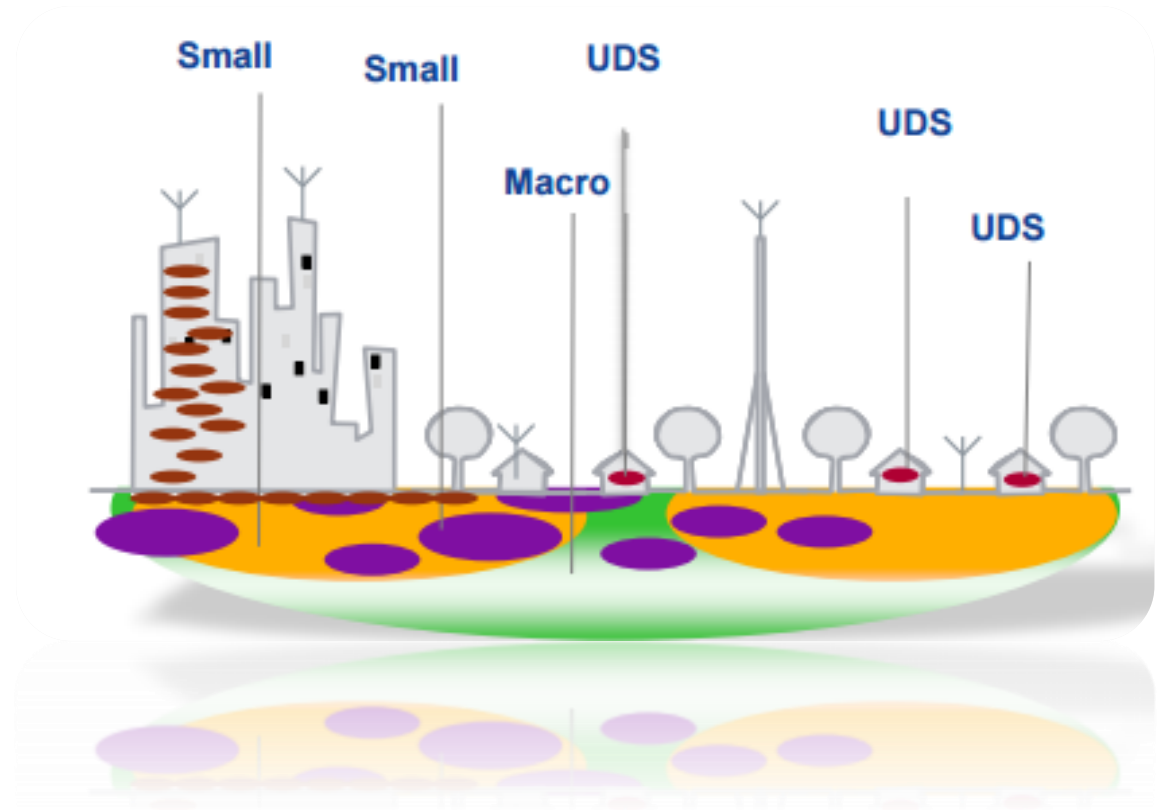

http://www.ieee-ctw.org/2014/slides/session1/Preben_Mogensen_230514_v3.pdf

Scenarios and Challenges

- Great Service in a Crowd
 - End-user demands for future communication solutions to work well in a crowd.
 - The technical challenge is **to provide such service at high traffic density per area despite a large number of UEs**, such as handsets and machines/devices per area in combination with deployment cost constraints.



Scenarios and Challenges

- Ubiquitous things communicating
 - This scenario addresses the **communication needs of a massive deployment of ubiquitous machine-type devices**, ranging from low complexity devices to more advanced devices.
 - Future networks expect **10 times to 100 times higher number of connected devices**, and **10 times longer battery life**.
 - The challenge is to meet the requirements of cost, energy consumption, transmission power, latency, that are not met by current technologies.



Scenarios and Challenges

- Best experience follows you
 - This scenario strives at bringing a similar user experience for users on the move, or for static users.
 - Challenges:
 - ✓ Robust and reliable connectivity solutions
 - ✓ Ability to efficiently manage mobility in the network



Scenarios and Challenges

- Super real-time and reliable connections
 - Machine-to-machine latency requirements are much more stringent than human communication requirements.
 - Applications: smart grids, e-health, efficient industrial communications, real-time tactile control, gaming!
 - Challenges:
 - ✓ Decrease 5 times the end-to-end latency
 - ✓ Latency reliability up to 99.999%

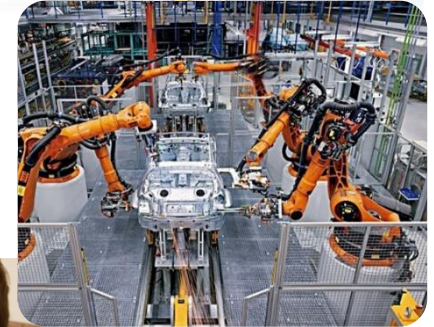

What are 5G requirements?

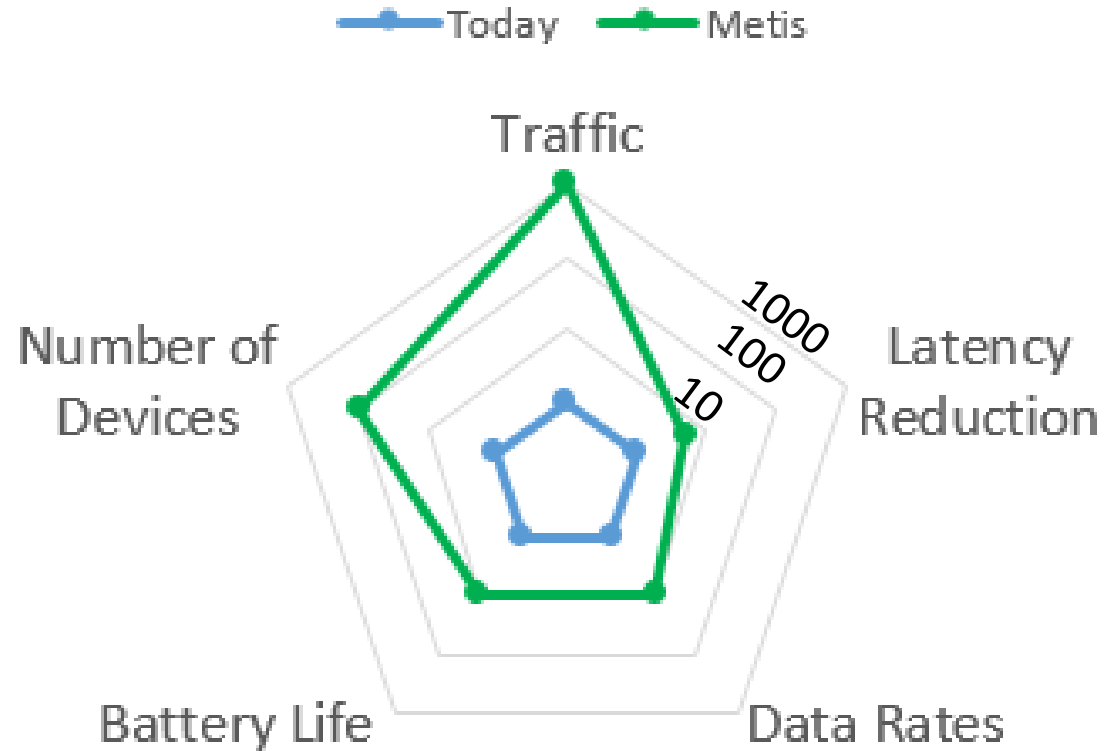

What are 5G requirements?

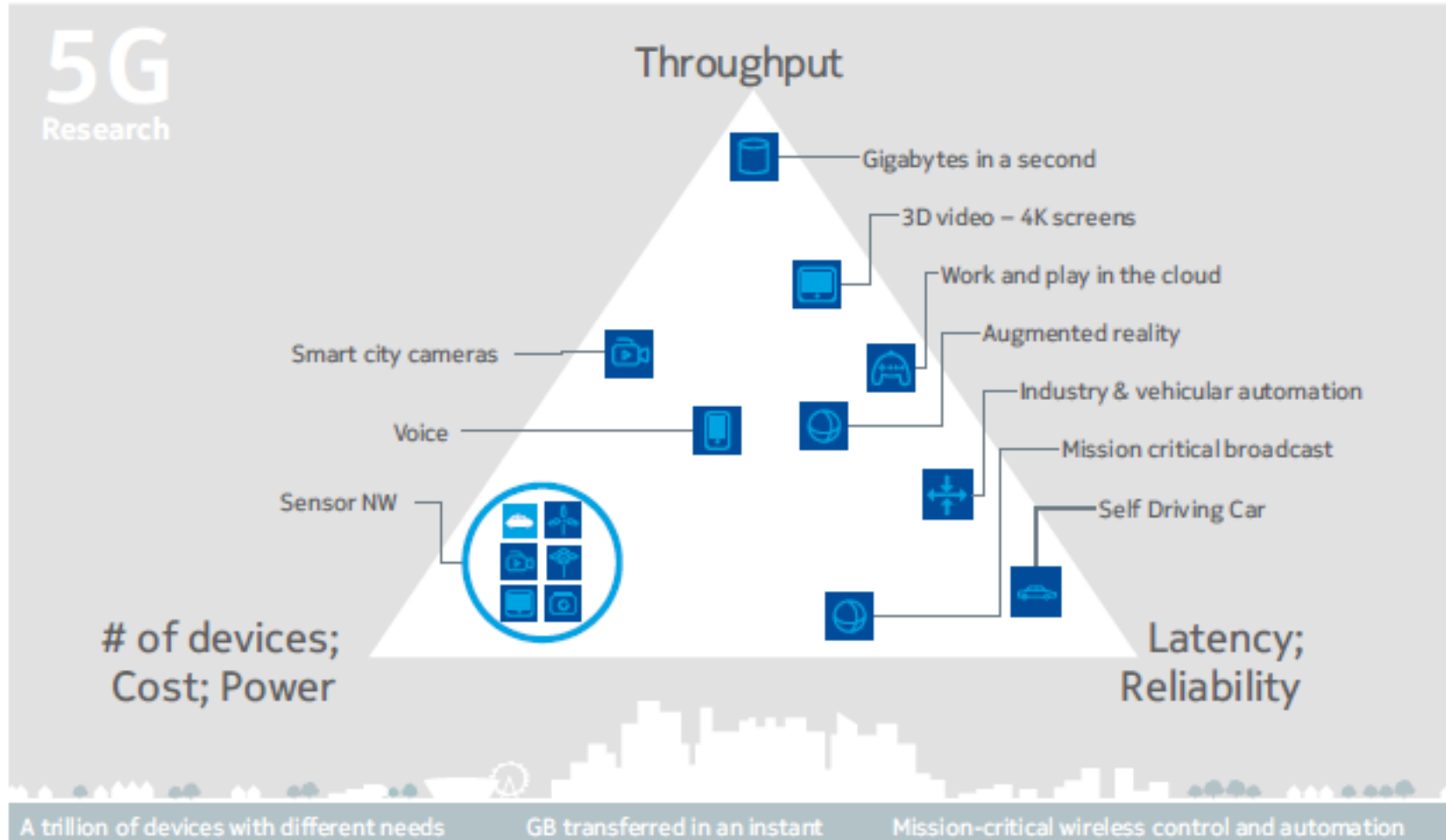

What are 5G requirements?

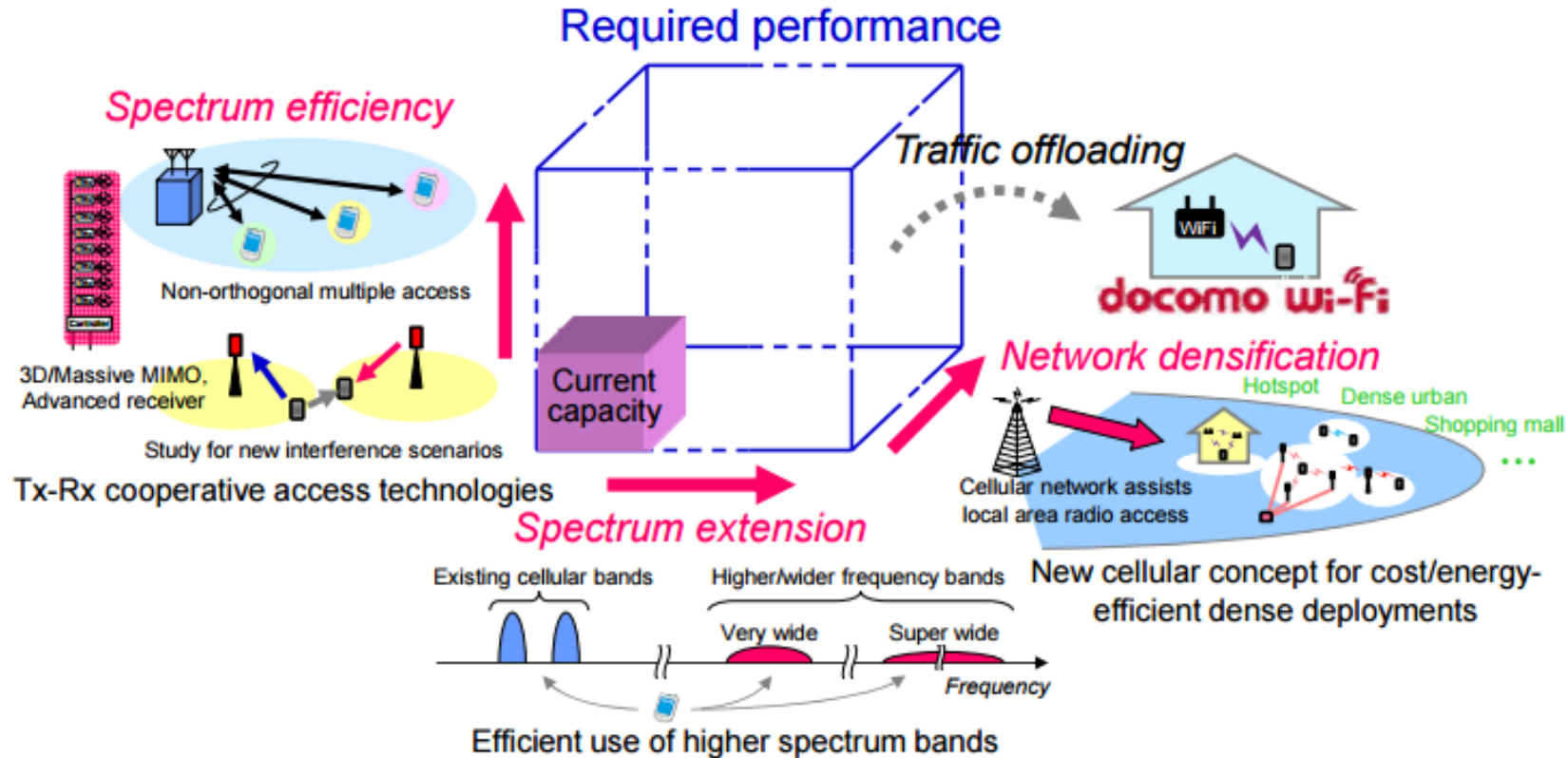

WHAT IS 5G?

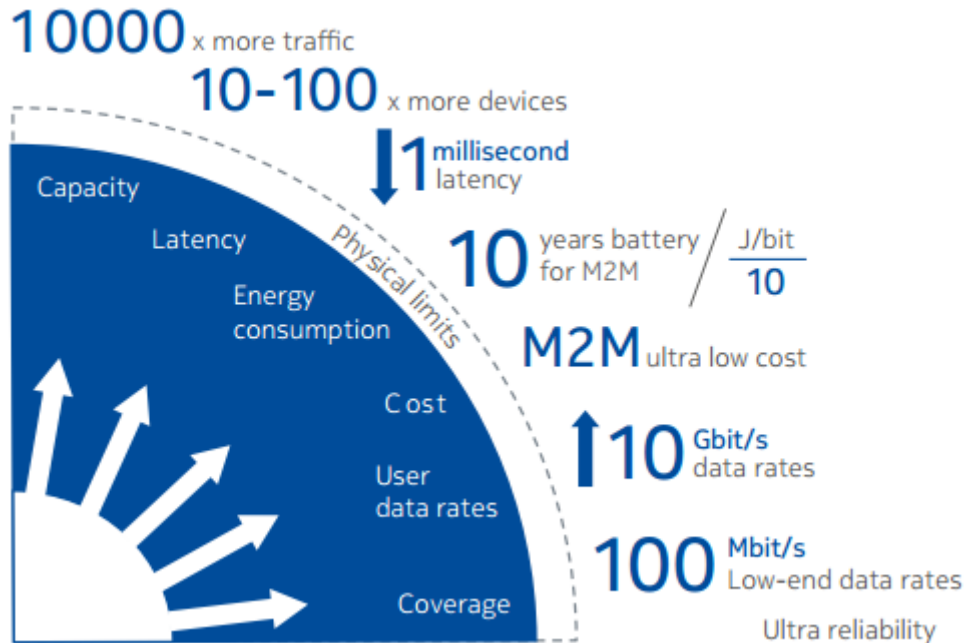

- Nokia believes that communications beyond 2020 will involve a combination of existing and evolving systems, like LTE-Advanced and Wi-Fi, coupled with new, revolutionary technologies designed to meet new requirements, such as virtually zero latency to support tactile Internet, machine control or augmented reality.
- 5G will be the set of technical components and systems needed to handle these requirements and overcome the limits of current systems



WHAT IS 5G?



- 5G is the next step in the evolution of mobile communication. It will be a key component of the Networked Society and will help realize the vision of essentially unlimited access to information and sharing of data anywhere and anytime for anyone and anything.
- 5G will therefore not only be about mobile connectivity for people. Rather, the aim of 5G is to provide ubiquitous connectivity for any kind of device and any kind of application that may benefit from being connected.

WHAT IS 5G?



- 5G wireless networks will support 1,000-fold gains in capacity, connections for at least 100 billion devices, and a 10 Gb/s individual user experience capable of extremely low latency and response times.
- Deployment of these networks will emerge between 2020 and 2030. 5G radio access will be built upon both new radio access technologies (RAT) and evolved existing wireless technologies (LTE, HSPA, GSM and WiFi). Breakthroughs in wireless network innovation will also drive economic and societal growth in entirely new ways.
- 5G will realize networks capable of providing zero-distance connectivity between people and connected machines.



WHAT IS 5G?



- **Understanding 5G**
The new GSMA report examines the two main views on 5G that exist today, which are frequently mixed together to form the basis of the 5G definition:
- ***View 1 – The hyper-connected vision:*** In this view, 5G is seen as a blend of existing technologies (2G, 3G, 4G, Wi-Fi and others) that can deliver greater coverage and availability, higher network density in terms of cells and devices, and the ability to provide the connectivity that enables machine-to-machine (M2M) services and the Internet of Things.
- ***View 2 – Next-generation radio access technology:*** This perspective outlines 5G in ‘generational’ terms, setting specific targets that new radio interfaces must meet in terms of data rates (faster than 1Gbps downlink) and latency (less than 1ms delay).



HOW WILL WE GET THERE?

How will we get there?

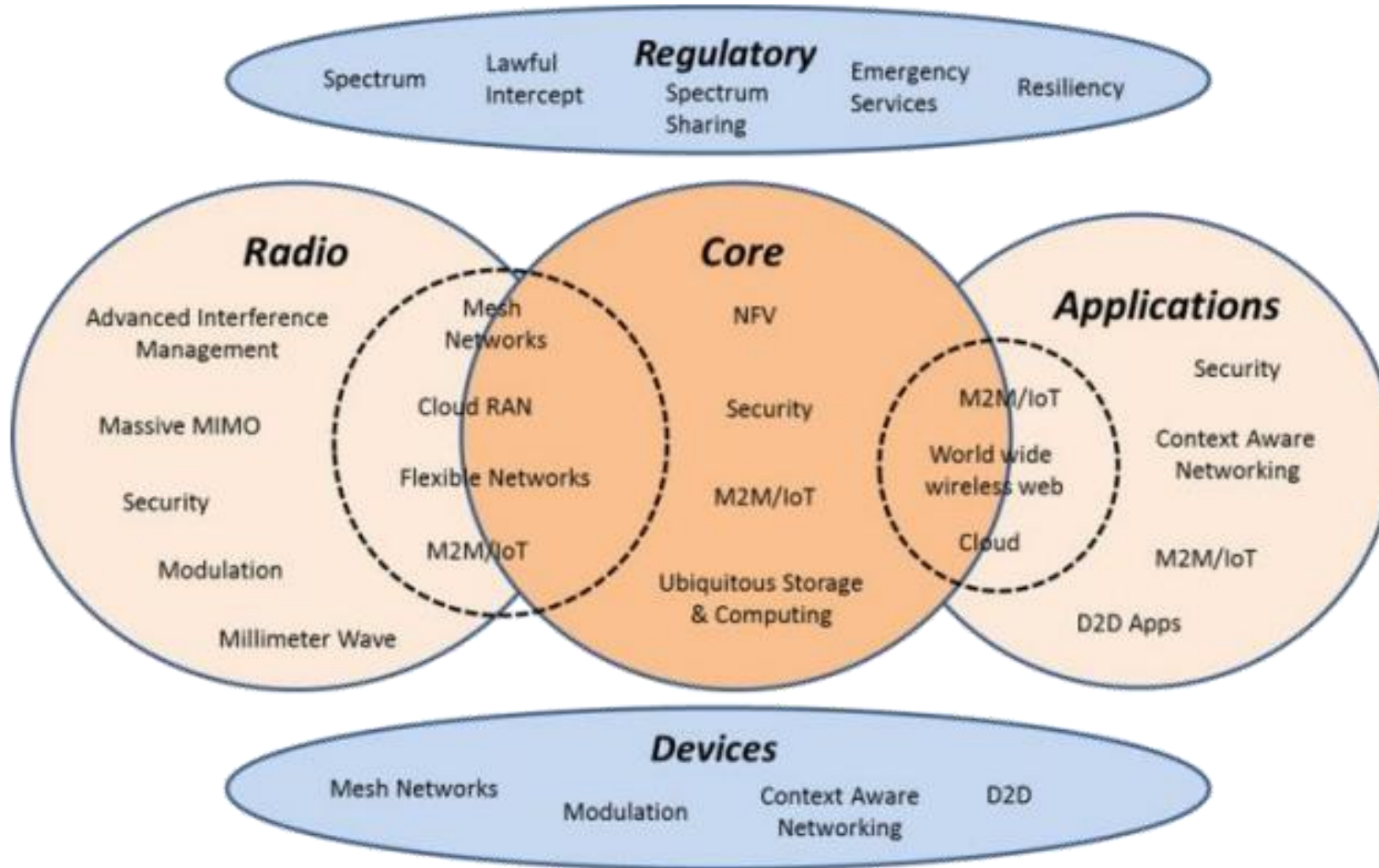

How will we get there

- Changes will be required in
 - Architecture
 - ✓ Radio Network
 - ✓ Core Network
 - Physical Layer
 - ✓ Multiple Access
 - ✓ Frame Structure
 - ✓ Modulation and Coding
 - ✓ More (Massive) MIMO
 - More Spectrum
 - ✓ cm Waves
 - ✓ mm Waves



ARCHITECTURE



4G Evolution

- Evolution usually does not happen out of the blue
It takes some time to go from here... ... to here.

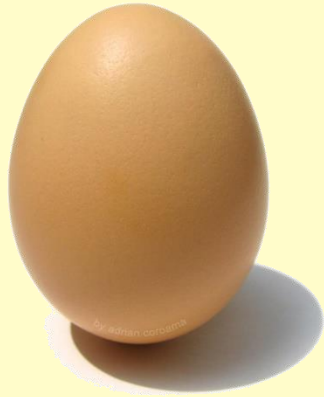

LTE architecture has been evolved
in most recent releases

4G Evolution

Network Architecture



3GPP Release 8 - 9

- SON: Automatic Neigh. , Handover Opt
- Home eNodeB

LTE ADVANCED

3GPP Releases 10

- SON: Drive Testing Minimization
- Carrier Aggregation

3GPP Releases 11-12

- SON: Network Energy Saving for E-UTRAN
- D2D Communications
- Small Cells

Beyond Release 12

- Small Cell Enhancements
- D2D Communications Enhancements
- Relay nodes



4G Evolution

Network Architecture



3GPP Release 8 - 9

- SON: Automatic Neigh. , Handover Opt
- Home eNodeB

LTE ADVANCED

3GPP Releases 10

- SON: Drive Testing Minimization
- Carrier Aggregation

3GPP Releases 11-12

- SON: Network Energy Saving for E-UTRAN
- D2D Communications
- Small Cells

Beyond Release 12

- Small Cell Enhancements
- D2D Communications Enhancements
- Relay nodes

MIMO

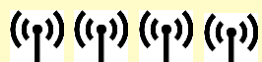



- 4x4 DL MIMO

- 8x8 DL MIMO
- 4x4 UL MIMO



- 8x8 UL MIMO

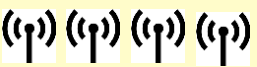

4G Evolution

		LTE ADVANCED			
		3GPP Release 8 - 9	3GPP Releases 10	3GPP Releases 11-12	Beyond Release 12
Network Architecture		<ul style="list-style-type: none"> SON: Automatic Neigh. , Handover Opt Home eNodeB 	<ul style="list-style-type: none"> SON: Drive Testing Minimization Carrier Aggregation 	<ul style="list-style-type: none"> SON: Network Energy Saving for E-UTRAN D2D Communications Small Cells 	<ul style="list-style-type: none"> Small Cell Enhancements D2D Communications Enhancements Relay nodes
MIMO		<ul style="list-style-type: none"> 4x4 DL MIMO 	<ul style="list-style-type: none"> 8X8 DL MIMO 4x4 UL MIMO 		<ul style="list-style-type: none"> 8x8 UL MIMO
Waveforms		<ul style="list-style-type: none"> OFDMA 			<ul style="list-style-type: none"> New Carrier Type

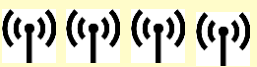
4G Evolution

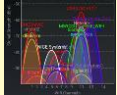
		LTE ADVANCED			
		3GPP Release 8 - 9	3GPP Releases 10	3GPP Releases 11-12	Beyond Release 12
Network Architecture		<ul style="list-style-type: none"> SON: Automatic Neigh. , Handover Opt Home eNodeB 	<ul style="list-style-type: none"> SON: Drive Testing Minimization Carrier Aggregation 	<ul style="list-style-type: none"> SON: Network Energy Saving for E-UTRAN D2D Communications Small Cells 	<ul style="list-style-type: none"> Small Cell Enhancements D2D Communications Enhancements Relay nodes
MIMO		<ul style="list-style-type: none"> 4x4 DL MIMO 	<ul style="list-style-type: none"> 8X8 DL MIMO 4x4 UL MIMO 		<ul style="list-style-type: none"> 8x8 UL MIMO
Waveforms		<ul style="list-style-type: none"> OFDMA 			<ul style="list-style-type: none"> New Carrier Type
Interference Management		<ul style="list-style-type: none"> ICIC 		<ul style="list-style-type: none"> COMP HetNet e-ICIC 	

4G Evolution

- Evolution usually does not happen out of the blue
It takes some time to go from here... ... to here.

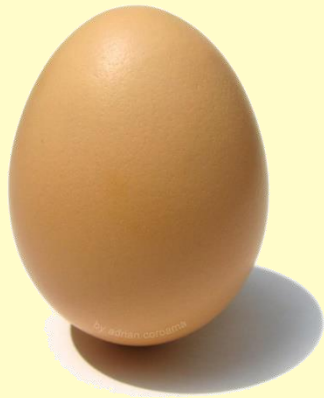

LTE architecture has evolved in most recent releases



But sometimes we need a **disruptive** technology

inthehallofmirrors.typepad.co.uk/.a/6a00d8341c345453ef019b0255f7a1970c-popup

So what's disruptive about 5G??

So what's disruptive about 5G??

- Nobody knows for sure, but here are a few possibilities

Ultra Dense Networks

- Cooper's law
 - Capacity of wireless systems double every 18 months
 - ✓ Most of it obtained by tighter spectrum reuse and smaller cells
 - Macro → Micro → Pico → Femto →
 - Ultra-dense Networks

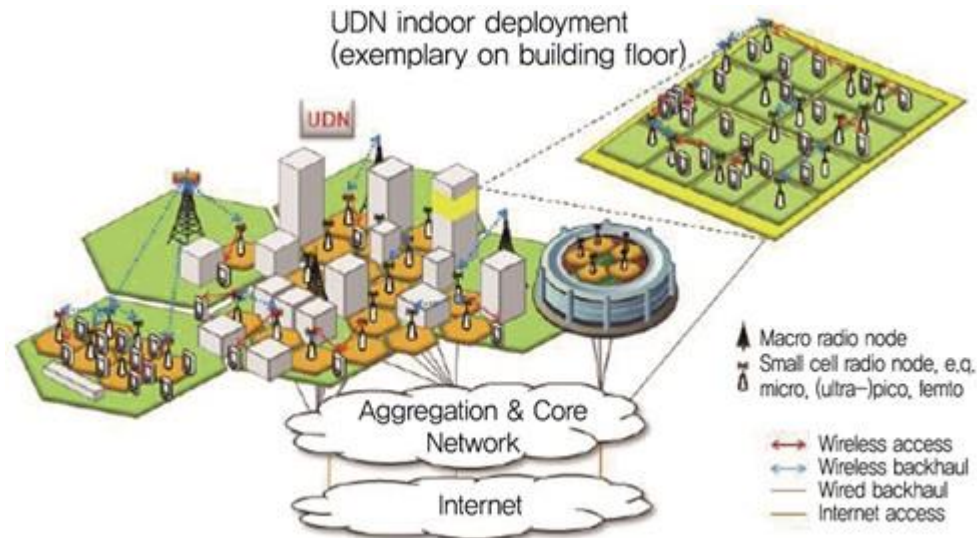

<https://ettrends.etri.re.kr>

CoMP (Coordinated MultiPoint)

- Extension of CoMP may be employed to make use of all its potential
 - using UE capabilities for interference cancellation
 - ✓ Reduces coordination at network
 - with massive MIMO

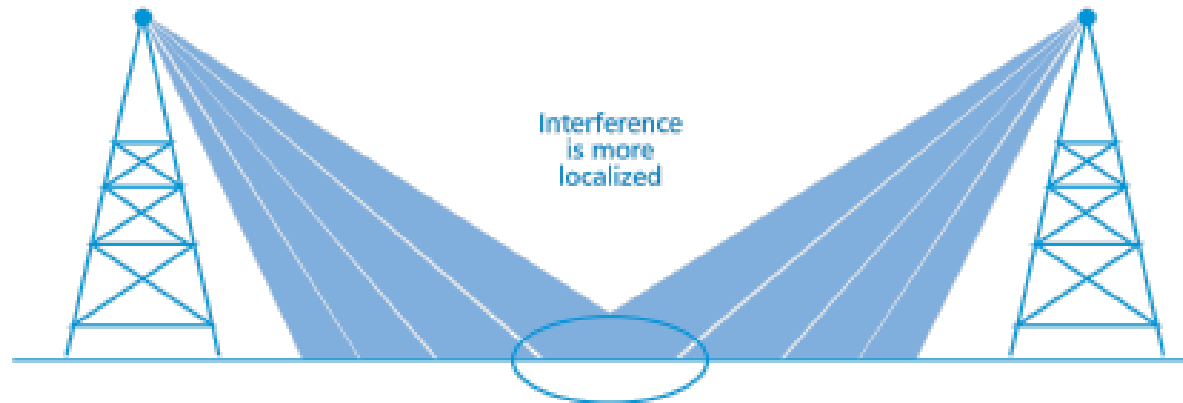

Jungnickel et al., IEEE Comm Mag., May 2014

Cloud RAN

- Networks are moving from a BS-centered to a cloud-based architecture
- Modem Signal processing moves to servers connected to the cloud
 - Distributed antennas with a centralized server

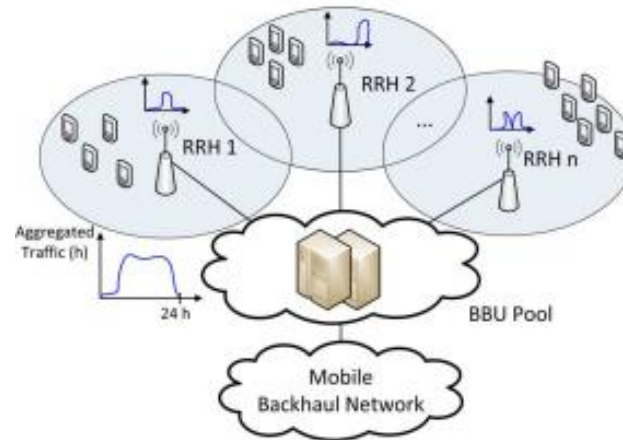

Checko et al., *Cloud RAN for Mobile Networks—A Technology Overview*, IEEE Comm. Surveys and Tutorials, 2015

Caching at RAN

- Popular content cache can be moved from network servers to packet core network and to radio network
 - NodeBs and even mobile terminals
 - ✓ Minimize backhaul traffic!
 - Distributed cache is an option
 - ✓ Using multicast coding, e.g. fountain codes
- Where to cache?
- What to cache?

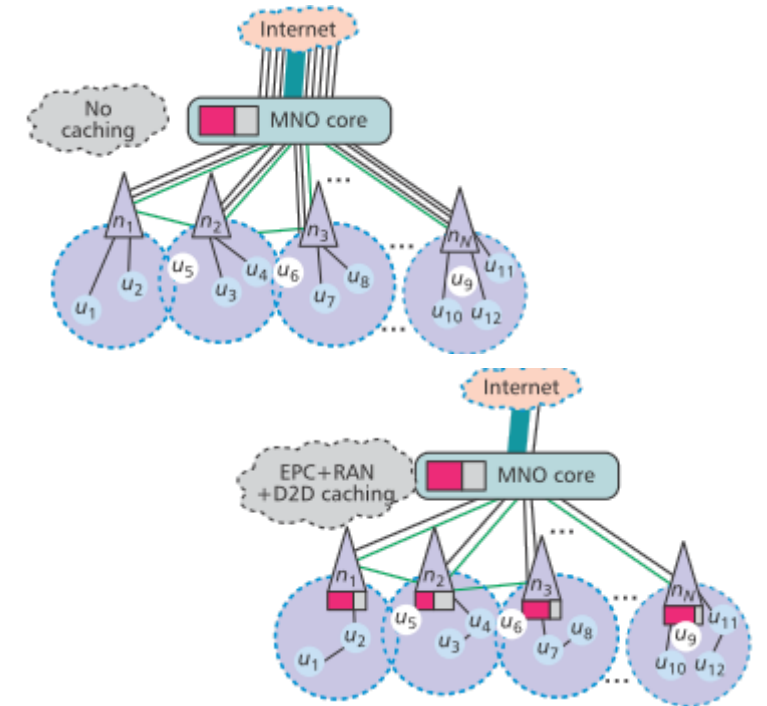

Wang et al., *Cache in the Air: Exploiting Content Caching and Delivery Techniques for 5G Systems*, IEEE Comm. Magazine, 2014

Device-to-Device (D2D)

- D2D is an essential technology for 5G (not an add-on, as in 4G)
 - Shorter links, hence lower transmit power, higher data rates
 - But more complex interference scenario
 - Needed for critical communications / emergency services
- Network-controlled D2D likely
- Challenges
 - Device Discovery
 - Beamforming
 - Interference management

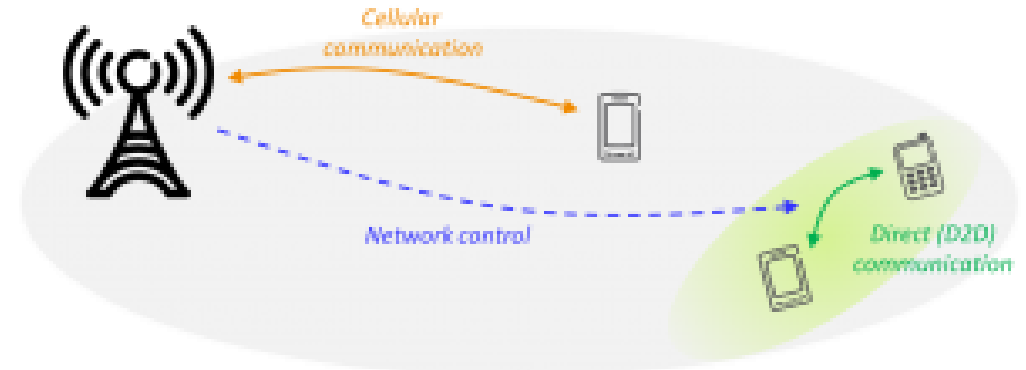

<http://www.ericsson.com/research-blog/5g/device-device-communications/>

MultiHop

- Multihop relays
 - Improve coverage and capacity
 - Reduce power consumption
 - May be essential for critical communications / emergency services
- Possibly with moving/temporary relays
 - Including device-to-device
- Dynamic routing algorithms are needed

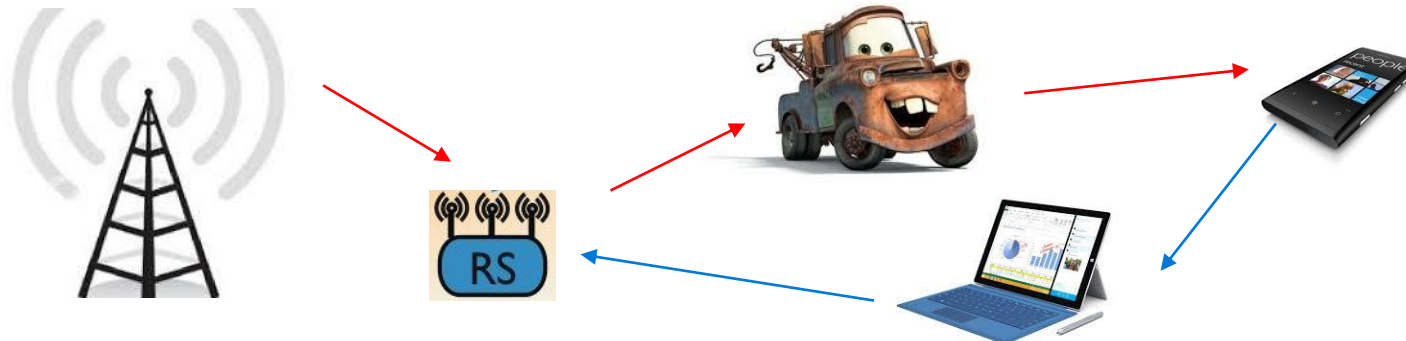

Phantom Cells

- User Plane and Control Plane will be separated
 - Signalling and resource management is done at macrocells
 - ✓ facilitates mobility management
 - Data transmission can be done at small cells at higher frequencies
 - ✓ Higher capacity
 - ✓ Lower energy consumption

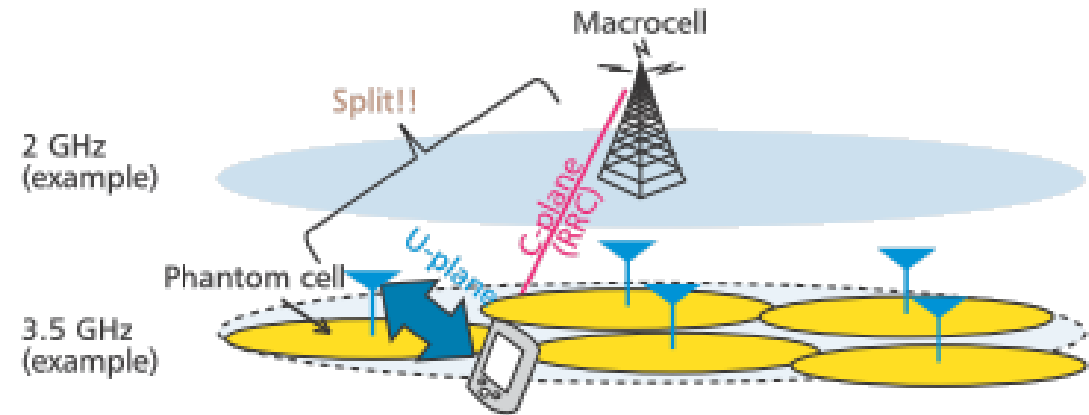

Nakamura et al., *Trends in Small Cell Enhancements in LTE Advanced*, IEEE Comm. Magazine, 2013

UL/DL decoupling

- Ideal serving cell can be different in Uplink and Downlink
 - In Uplink low-power transmission from UE favours nearby small cells
 - In Downlink, high-power transmission and multiple antennas configuration may favour larger cells
 - Depends also on traffic load in each cell
 - Results in higher throughput/ lower energy consumption

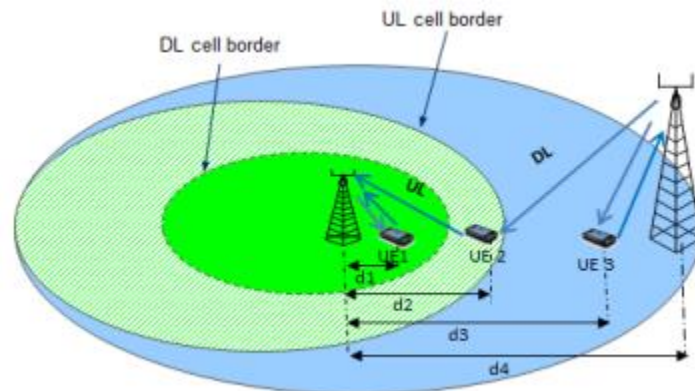

Elshaer et al., *Downlink and Uplink Decoupling: a Disruptive Architectural Design for 5G Networks*, Globecom 2014

- Enabler technology for Intelligent Transportation Systems
 - Vehicle-to-vehicle (v2v)
 - Vehicle-to-Roadside infrastructure (v2i)
 - and beyond (v2x), e.g., vehicle-to-pedestrians
- D2D is enabler
- **Latency and reliability are critical!**
- But high mobility is a complicator
 - For PHY (Doppler spread)
 - For MAC (resource assignment)
 - For Routing / mobility management

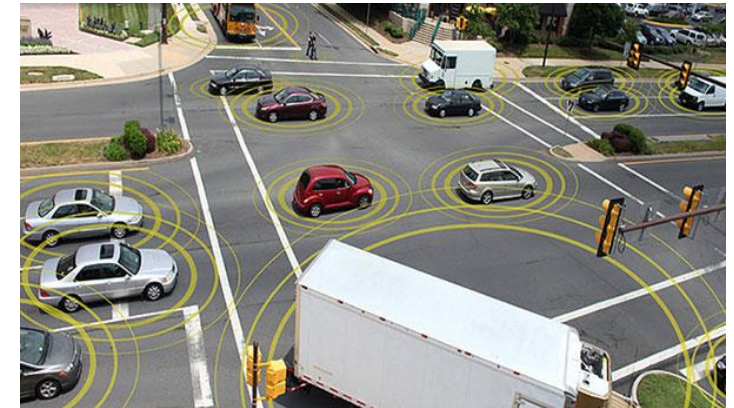

<https://autoskills.aaa.com/web/aaa/blog/-/blogs/v2x-challenges-to-deployment>

Moving Networks

- Mobile Femtocells may be installed in vehicles
 - E.g, Trains, Trams and Buses
 - Can be seen as moving relay stations
- Lower energy consumption
- Higher spectral efficiency
- Reduced handover signalling
- But dynamic backhaul is a challenge



Haider et al., *A Simulation Based Study of Mobile Femtocell Assisted LTE Networks*, IWCMC 2011

Cell Sleep Mode

- Cells may be switched off when low/no traffic demand
 - High potential energy savings!
 - Reduced backhaul
 - Traffic load may vary a lot, particularly for small cells
 - ✓ Fast and reliable algorithms must be devised



Intel, *Towards Future 5G Mobile Networks*, Intel, Globecom 2014

Self-Organizing Networks (SON)

- 5G is characterized by:
 - heterogeneous networks
 - different backhaul technologies
 - ultra-dense scenarios,
 - flexible requirements,
 - changing environment (relays, nomadic nodes, energy saving mode)
- Too complex for manually operation, SON must be taken to a new level
 - Differently from 3G/4G networks, SON is not an option for 5G, but mandatory



- Challenges for SON
 - End-to-end network visibility
 - Small and large time scales
 - Focus on energy efficiency
 - Definition of the right KPIs
 - Faster action – from reactive to proactive

Massive Machine-Type Communications

- Radio Access for Internet-of-Things
- Support for tenths of billions of devices
- Each BS should keep registration of hundreds/thousands of devices
 - Many low-power devices (are off most of the time)
 - Signalling load must be kept to the bare minimum
 - Support for both connection-oriented/connectionless approach
 - Possibly unsynchronised devices
 - Contention/reservation based?

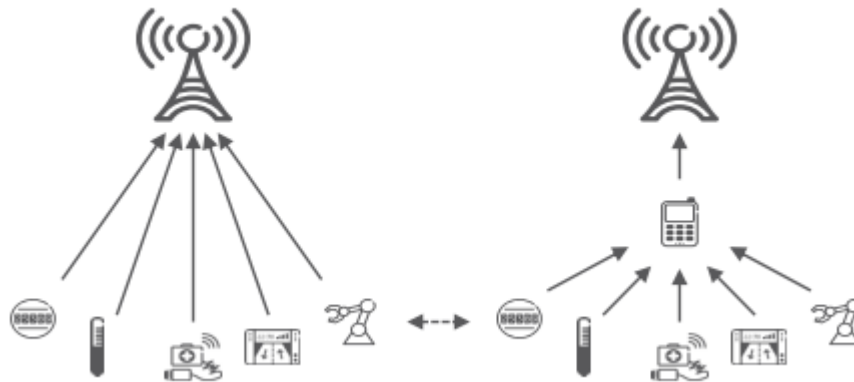

Wireless Backhaul

- 5G will rely on UDN with very large number of network nodes
 - It is not feasible to install fiber links to all of them
 - Some nodes may be moving
- Wireless backhaul is essential!
- Using Massive MIMO / millimeter waves
 - Very directive links
 - Very large bandwidths (several GHz)

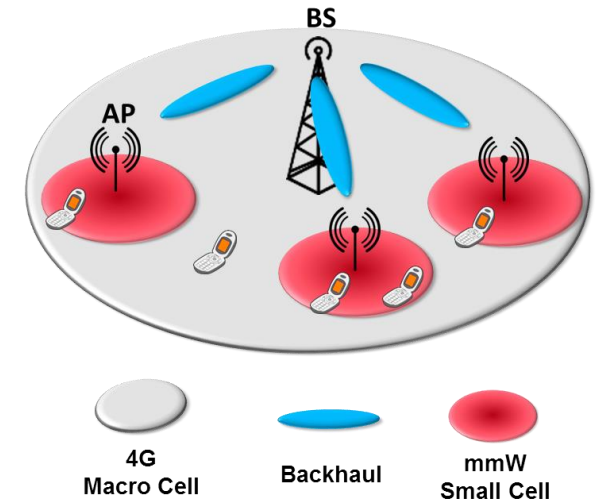

<http://www.miwaves.eu/>

Mobility Management

- Use of small cells pose a challenge for handover
 - Control/user plane Split (phantom cells) help reduce handover overhead
 - UE-autonomous handover
 - ✓ decision can be made by EU instead of network
 - ✓ But with network assistance / prediction
- Moving networks is also a challenge
 - But helps reduce HO signalling
- Directive links in mmWave are also a complicator

Context Awareness

- Context Awareness may help resource allocation
- Context includes:
 - Location Information
 - Predictive approaches
 - ✓ traffic
 - ✓ coverage
 - ✓ channel state information
 - ✓ trajectory
 - QoS requirements

Other Issues

- Some very important issues are not covered here
 - Security
 - ✓ for cheap low-complexity machine-type devices
 - ✓ For safety-critical communications (e.g., V2X)
 - AAA (Authentication, authorization and accounting)
 - ✓ different technologies, possibly different network operators
 - OAM (Operations, Administration and Maintenance)
 - SDN (Software-Defined Networks)
 - ✓ Essential for core network

FRAME STRUCTURE



Duplexing

- So far, communication systems duplex signals either in time or in frequency, due to technical difficulties in implementing full-duplex integrated circuits.
- Consider LTE, for example, where two frame types are defined:
 - Frame Format 1: FDD
 - Frame Format 2: TDD

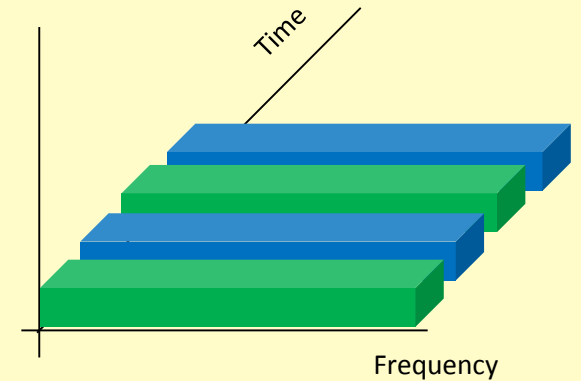

TDD

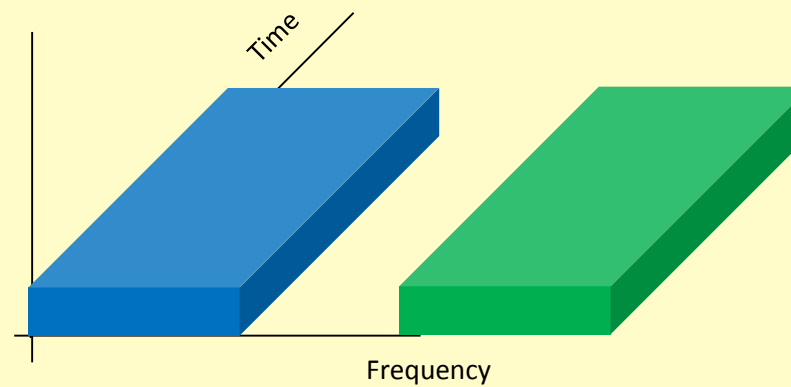
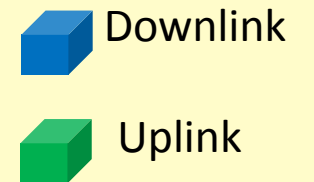

FDD



LTE Frame Type 1

- LTE Frame Type 1
 - FDD frame: two frequency bands are needed...

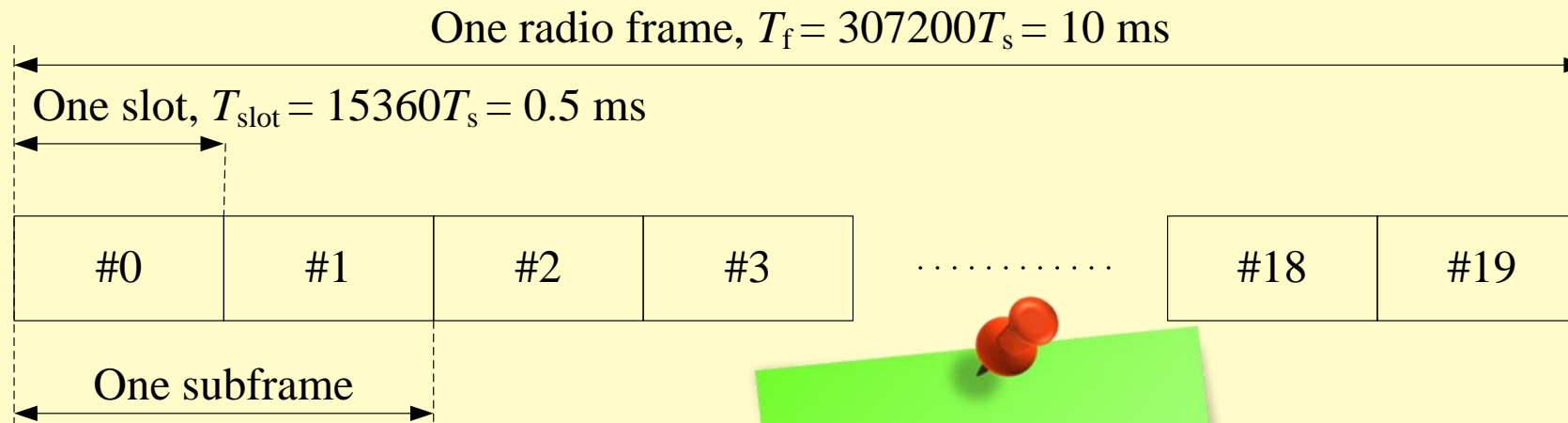

1. TTI = 1 ms
2. HARQ retransmissions: 8 ms
3. 4 ms delay considered in UE processing

LTE Frame Type 2

- LTE Frame Type 2 (TDD) :

Special Subframes:
transition between
Downlink and Uplink
Frames. Contain both
uplink and downlink data
and a guard period
between both.

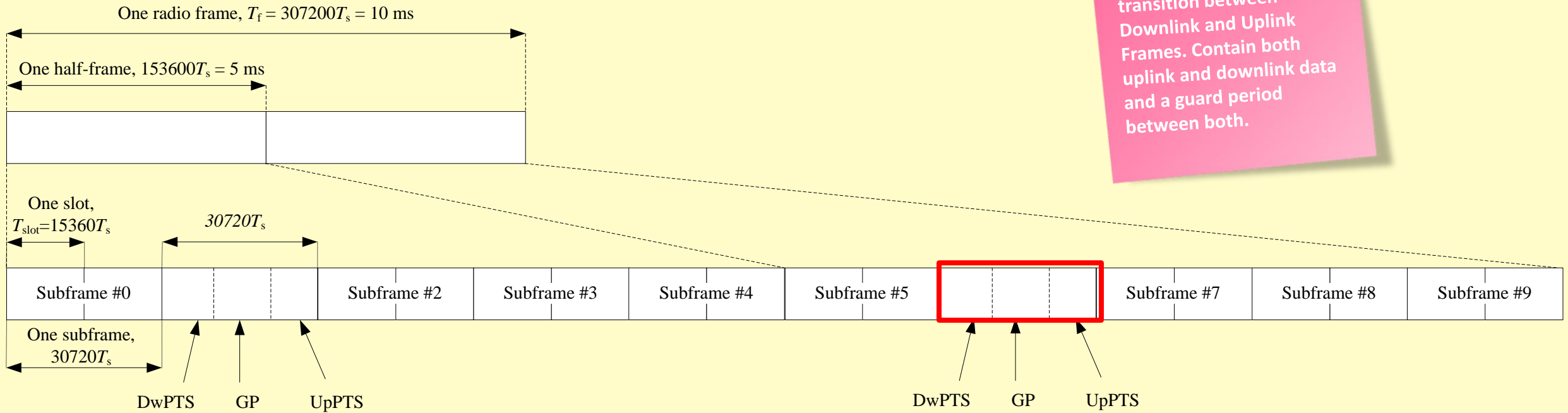

LTE Frame Type 2

- TDD frames also contain a certain proportion of subframes used for DL and UL, as given in the table below.
- Change in pattern may occur periodically e.g. 640 ms
- Only 7 combinations are available...

Uplink-downlink configuration	Downlink-to-Uplink Switch-point periodicity	Subframe number									
		0	1	2	3	4	5	6	7	8	9
0	5 ms	D	S	U	U	U	D	S	U	U	U
1	5 ms	D	S	U	U	D	D	S	U	U	D
2	5 ms	D	S	U	D	D	D	S	U	D	D
3	10 ms	D	S	U	U	U	D	D	D	D	D
4	10 ms	D	S	U	U	D	D	D	D	D	D
5	10 ms	D	S	U	D	D	D	D	D	D	D
6	5 ms	D	S	U	U	U	D	S	U	U	D

LTE Frame: DL Physical data & Control Channels

1 Radio Frame (10 ms) / 10 Subframes / 10 TTIs (1MS) / 140 Symbols
(normal CP / Antenna Port 0 / 2x2 MIMO / 3 OFDM Symbols for PDCCH)

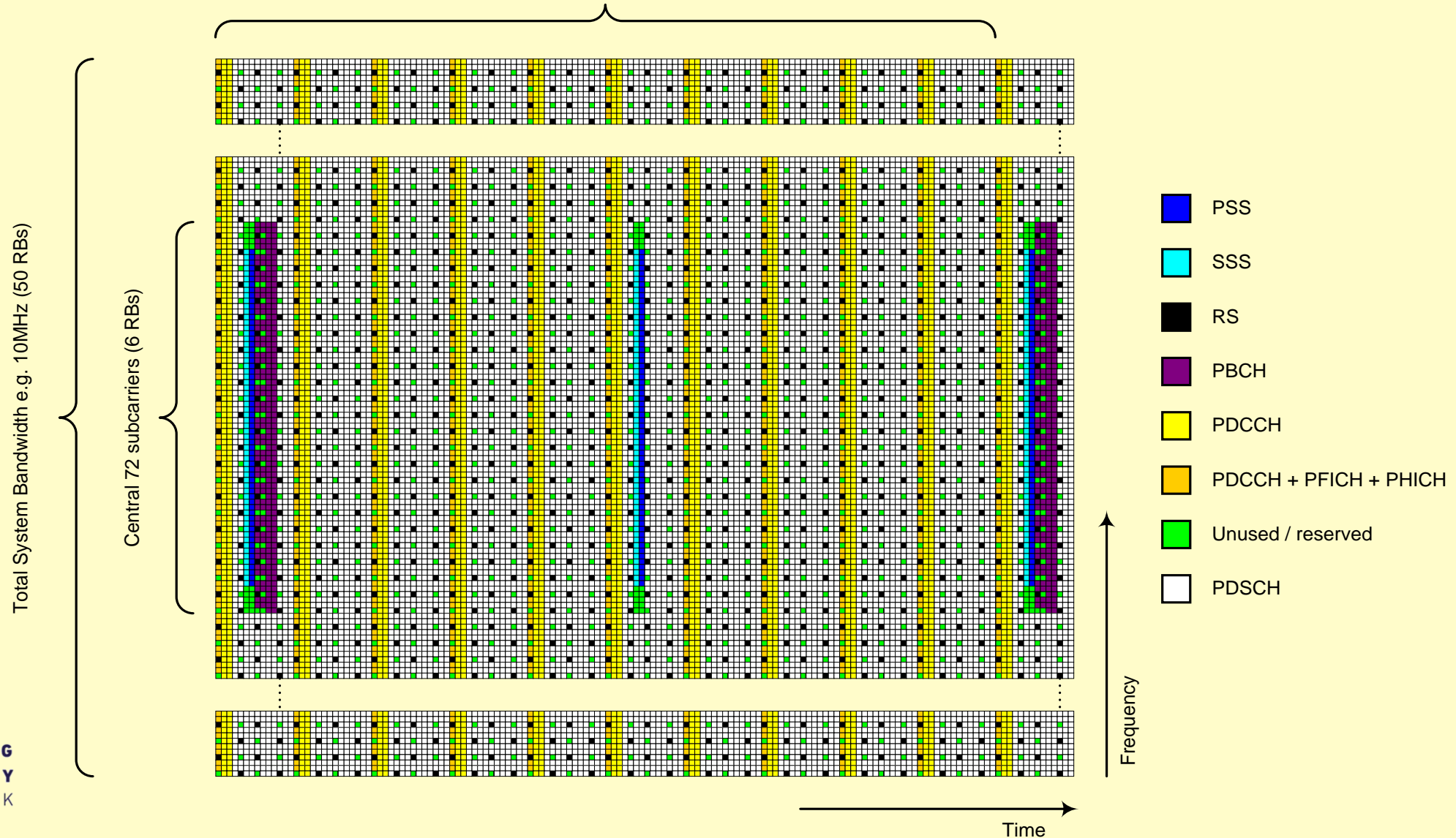

LTE Frame: DL Physical data & Control Channels

1 Radio Frame (10 ms) / 10 Subframes / 10 TTIs (1MS) / 140 Symbols
(normal CP / Antenna Port 0 / 2x2 MIMO / 3 OFDM Symbols for PDCCH)

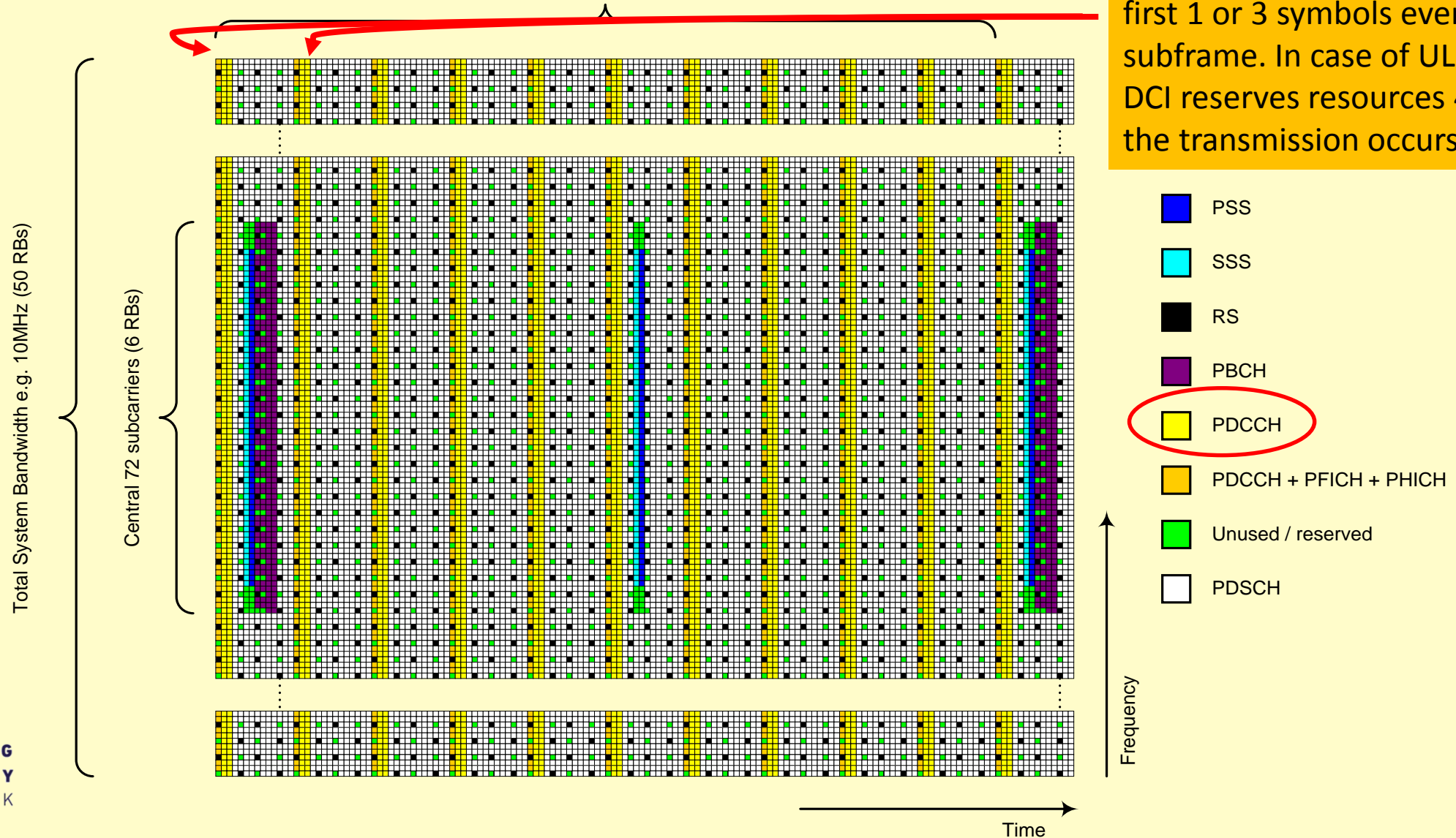

Allocation information goes in the first 1 or 3 symbols every subframe. In case of UL scheduling, DCI reserves resources 4ms before the transmission occurs (FDD)

- PSS
- SSS
- RS
- PBCH
- PDCCH
- PDCCH + PFICH + PHICH
- Unused / reserved
- PDSCH

What about 5G frame format?

- It is not defined yet, but we know that:
 - Latency should be reduced
 - A lot of different applications must be supported, take for example:
 - ✓ Broadband connections with large packets and high data rate.
 - ✓ Sensors with small packets and low energy consumption.
- Some proposals were already made:
 - Dynamic TDD
 - Full Duplex frame

Dynamic TDD

- The proportion of UL and DL frames is not fixed. Any configuration is possible.
 - Separation of Control Channels and Data Channels.
 - ✓ Short guard period inserted every switch of transmission direction
 - ✓ Cost-effective pipeline processing at the receiver
 - ✓ Reduced Latency
 - The first symbol in the data part is reserved for transmission of DMRS (DeModulation Reference Sequence) : to enable channel estimation at the receiver.

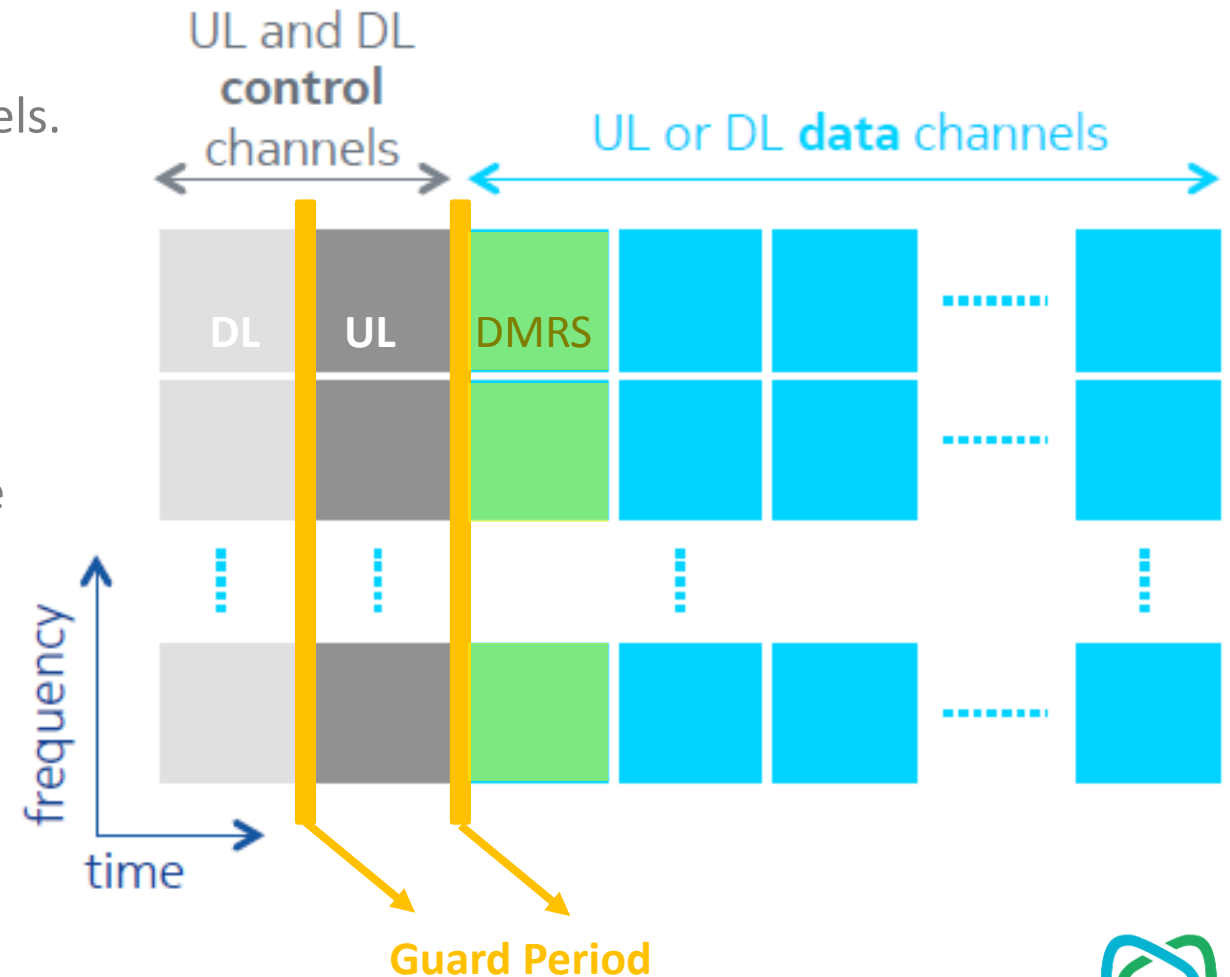

Dynamic TDD

- Frame length is assumed to be 10 times lower than LTE's
 - Overall latency in the order of 1 ms
- Uses the same access technique for both DL and UL:
 - Easy multihop,
 - self-backhauling
 - direct device-to-device communication in a cost-efficient way
- Challenges
 - Synchronization
 - Interference

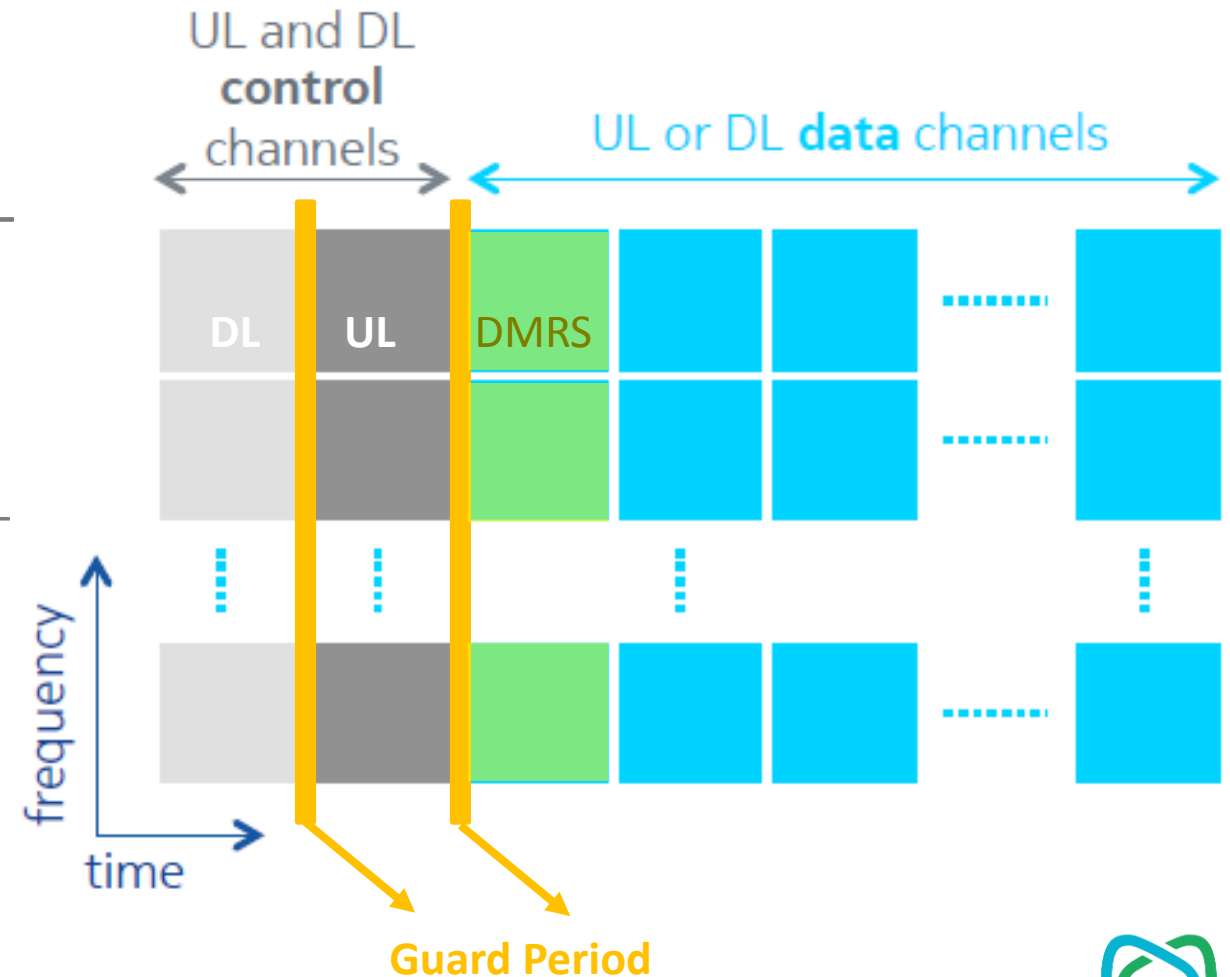

Full Duplexing

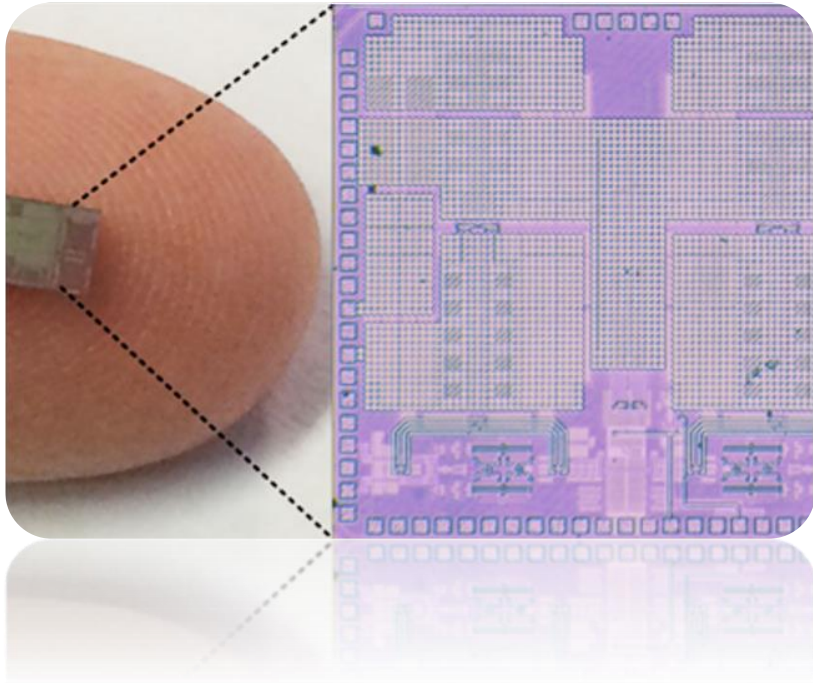

- Another proposal to meet 5G requirements is the use of full duplex radios.
- Challenges
- Self-interference cancellations
 - Antenna Cancellation using asymmetric placement of TX
 - Analog cancellation with cancellation circuits that reconstruct a copy of transmitted signal and subtracts it.
 - Digital cancellation
- DL to UL Interference mitigation
- Battery usage

Unified uplink frame structure

- Unified uplink frame structure
 - Enables mix of synchronous and asynchronous and orthogonal / non-orthogonal traffic types
 - High volume data transmission and high-end spectral efficiency still exploits orthogonality and synchronism wherever possible (Type 1 and 2).
 - Sporadic traffic type exploits contention-based access technique (Type 3)
 - Sensor type traffic would stretch the transmissions in time, for it is an energy efficient approach (Type 4)

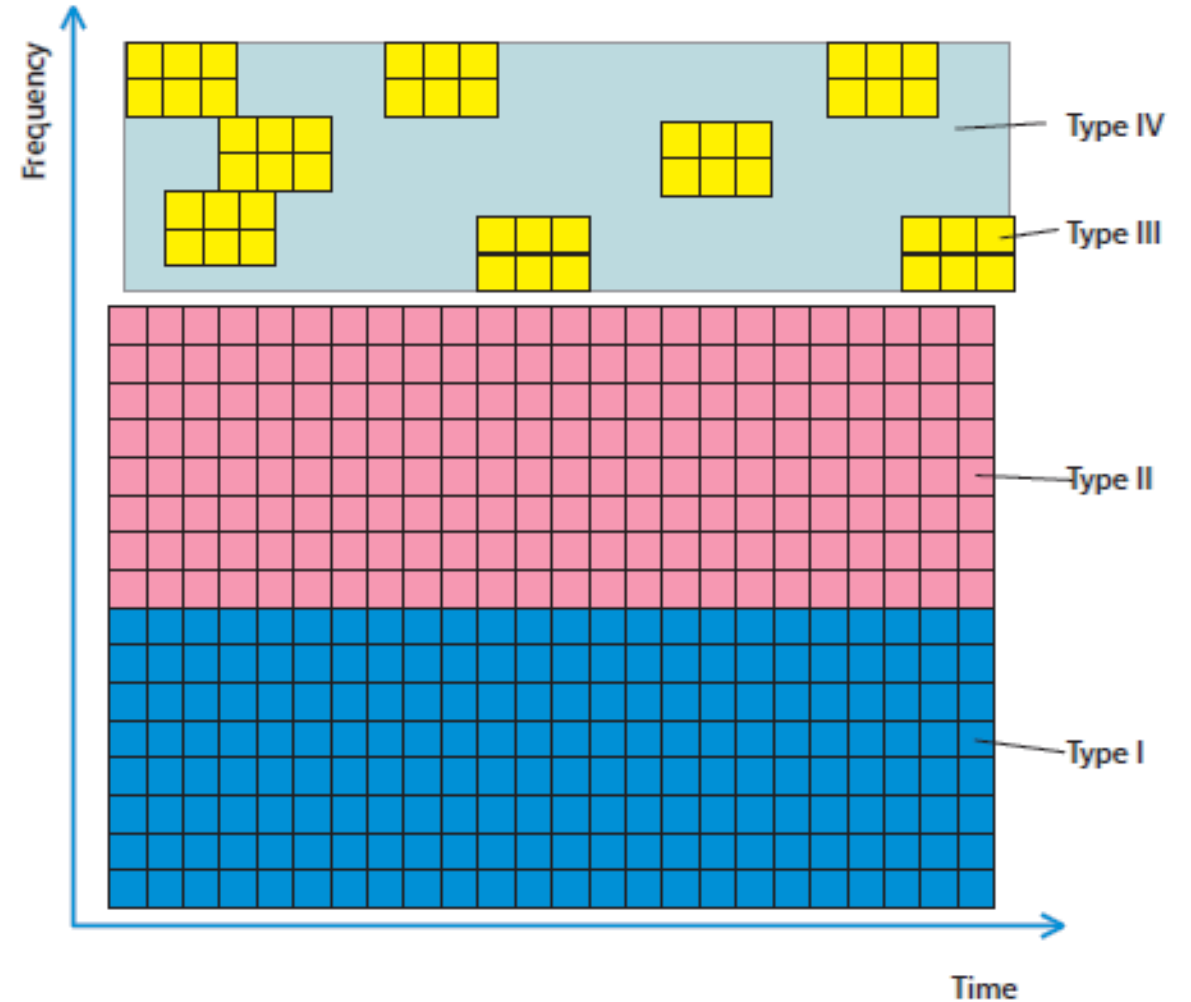

AIR INTERFACE MODULATION AND CODING



OFDM (Orthogonal Freq. Div. Mux.)

- OFDM is the currently preferred technique for broadband wireless
 - 4G (3GPP-LTE), WiFi (IEEE 802.11), Digital TV (DVB/ISDB), among others
- Reduced and fixed equalization complexity for large number of multipaths (depends on FFT size)

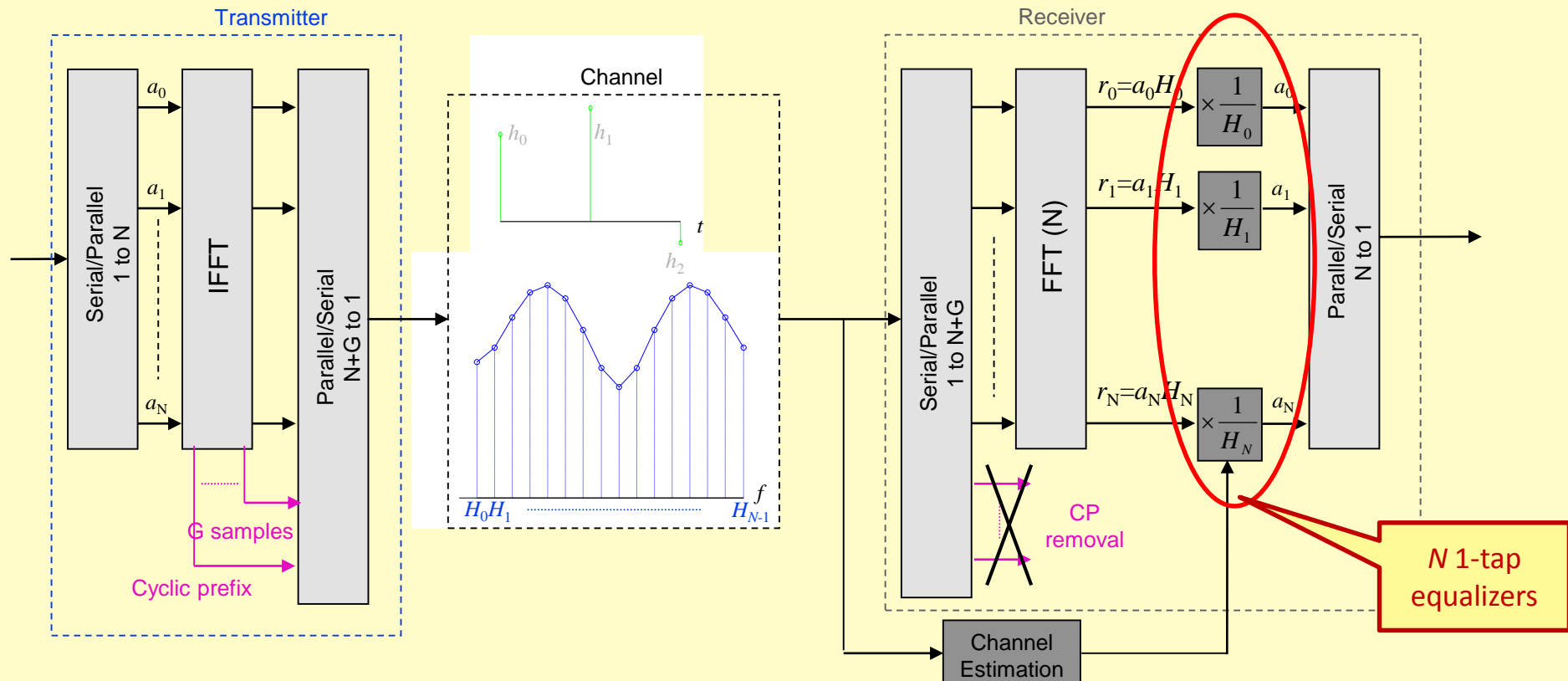

OFDMA (Ort. Freq. Div. Multiple Access)

- Flexible resource allocation
- Frequency-domain resource assignment is possible
 - If channel state information is known
 - Allows multiuser diversity

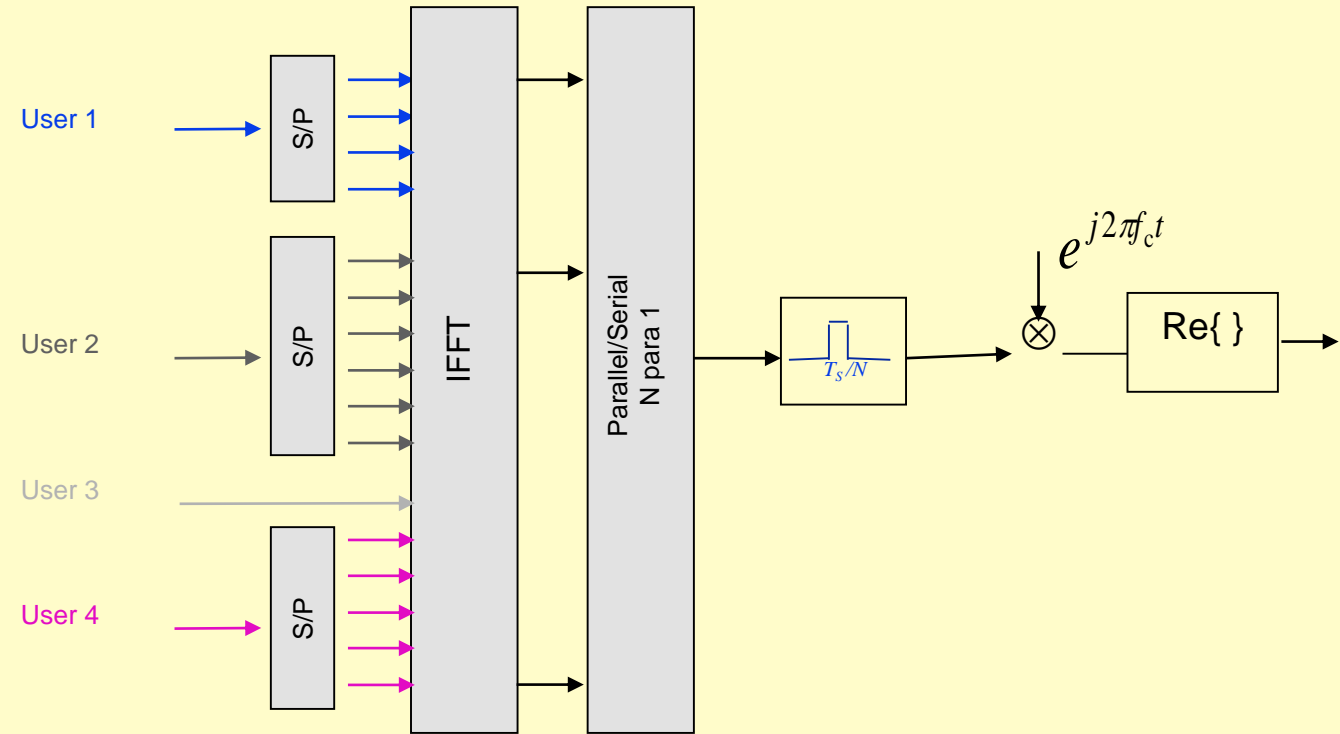

SC-FDE (Single-Carrier Freq. Domain Equalization)

- OFDM has a large Peak-to-Average Power Ratio (PAPR)
 - Power amplifiers must be overdimensioned and operate inefficiently
 - Especially unfavourable for UL, transmitting user equipments (UE)
- Blockwise Frequency-Domain Equalization approach can also be applied to single-carrier modulation (if guard interval is included)

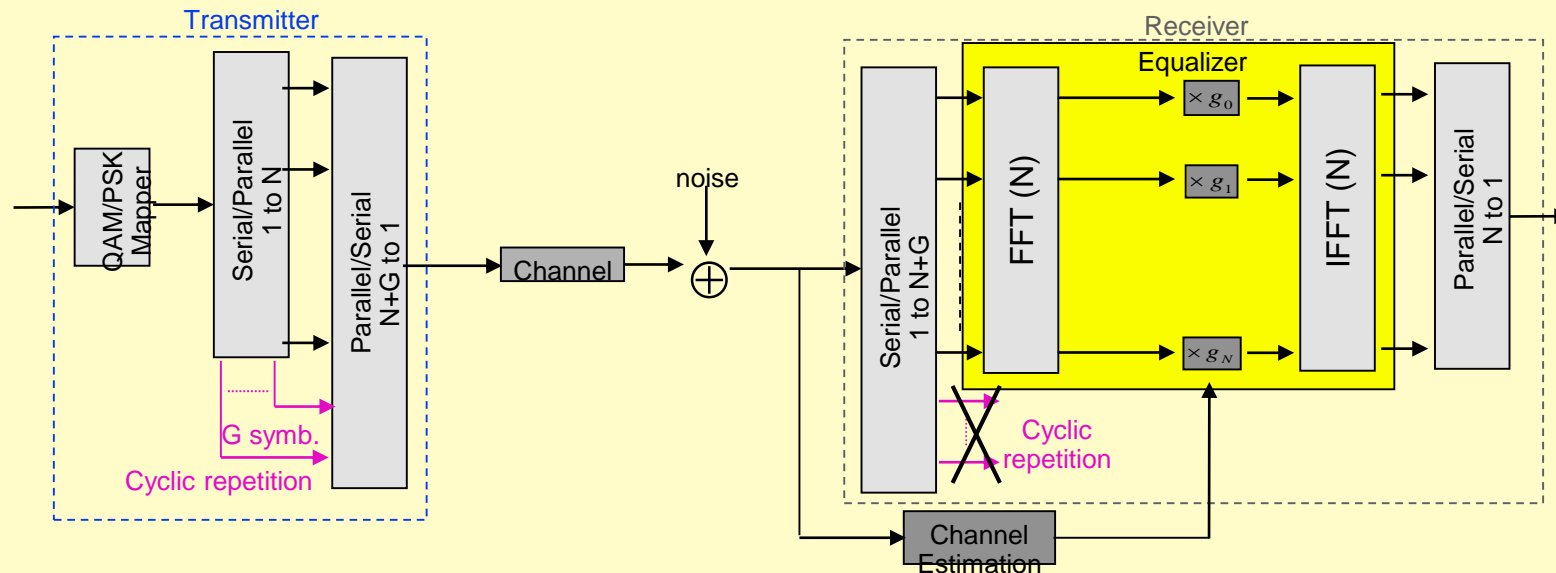

SC-FDMA

- Multiple users can be allocated to different subcarriers by applying a DFT on the single-carrier signal
- Also known as DFT-spread (DS) OFDM
- Used in 4G Uplink

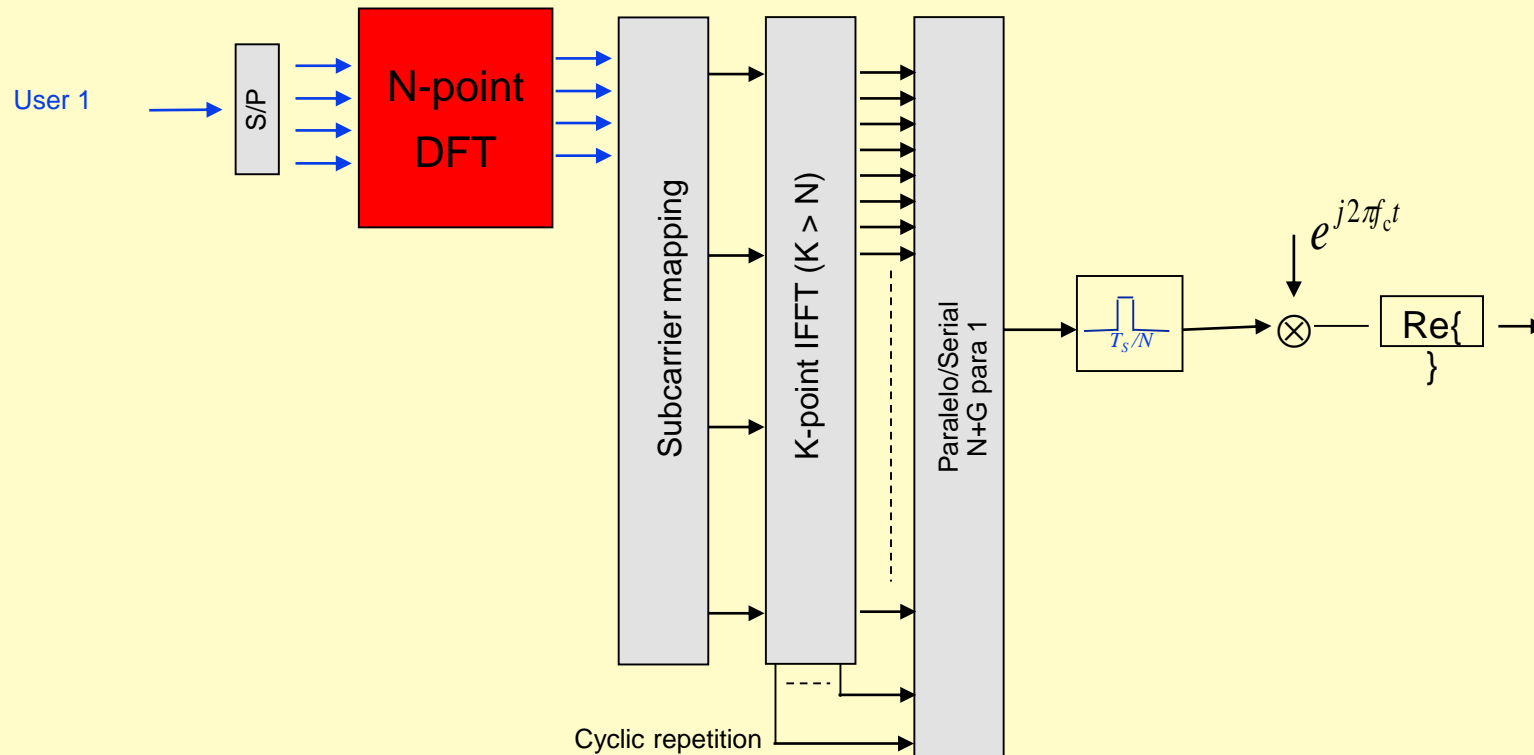

Do we need a new waveform?

■ Different scenarios

- Below 3GHz

- ✓ “business as usual” (for now)

- $3\text{GHz} < f < 30\text{GHz}$ (cmWaves)

- ✓ Ultra-dense Networks

- ✓ Many different types of users

- $>30\text{GHz}$ (mmWaves)

- ✓ Beamforming

- Low interference

- Small delay spread

Do we need a new waveform?

■ Motivations

- Spectral containment
 - ✓ Well-defined sub-bands (flexibility)
- Loose synchronization requirements
 - ✓ Less PRACH interactions (lower faster signalling)
 - ✓ Particularly relevant for machine-type communications
- OFDM has some drawbacks
 - ✓ Relatively large sidelobes
 - ✓ Requires time/frequency synchronization to maintain orthogonality

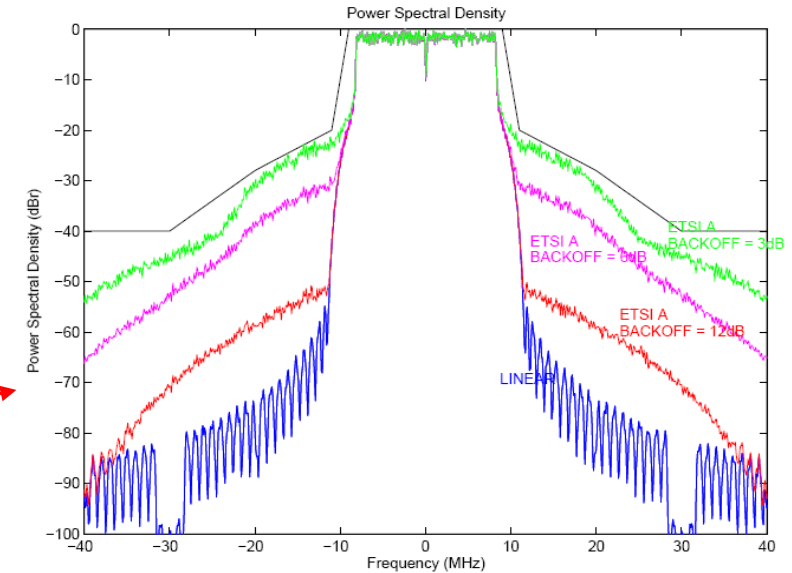

■ Most likely one single technique for all links

- Use of D2D / V2X / multihop eliminates the distinction between UL/DL
- Makes interference cancellation easier

New Waveforms

- Several candidates are being proposed in the literature
 - FBMC UFMC
 - GFDM
 - ZT-DS-OFDM
 - Faster-than-Nyquist

FBMC (Filterbank Multicarrier)

- Each subcarrier is filtered by a frequency shifted prototype filter
- OFDM is actually a particular case of filter-bank modulation
 - Prototype filter is a `rect` (in time domain) / `sinc` (in frequency domain)
 - ✓ with large sidelobes
 - ✓ But orthogonal subcarriers
- Other prototype filters with lower out-of-band radiation may be used
 - But orthogonality may be lost
 - More efficient with OQAM

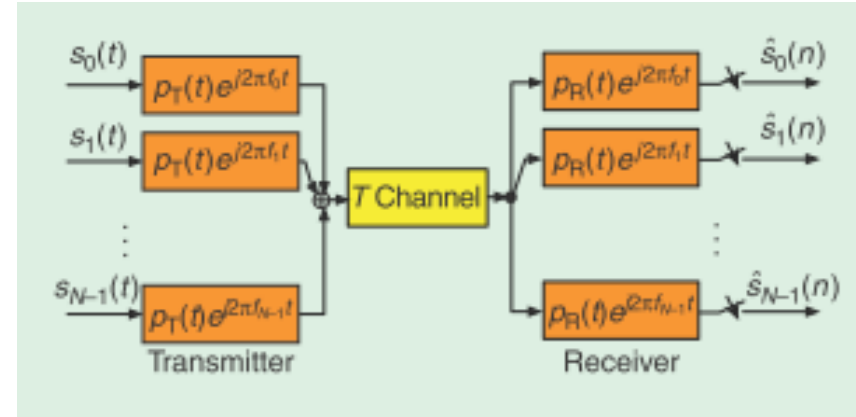

Farhang-Boroujeny, *OFDM versus Filterbank Multicarrier*, IEEE Signal Proc. Mag., 2011.

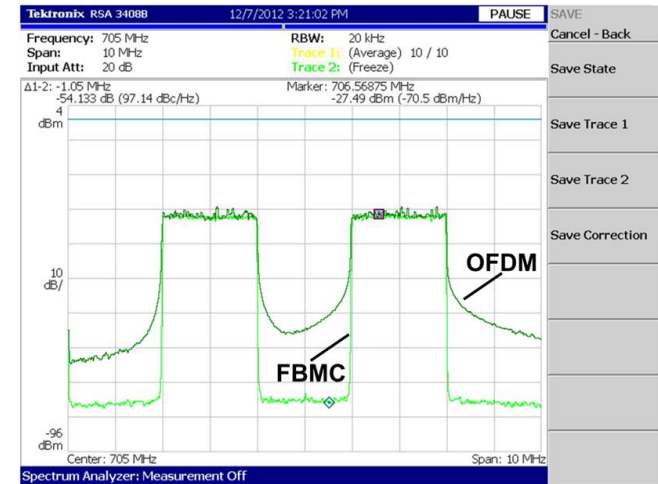

<http://www.ict-qosmos.eu/>

UFMC (Universal Filterbank Multicarrier)

- It's an extension of FBMC
- Filter is applied on blocks of OFDM subcarriers instead of on each individual subcarrier

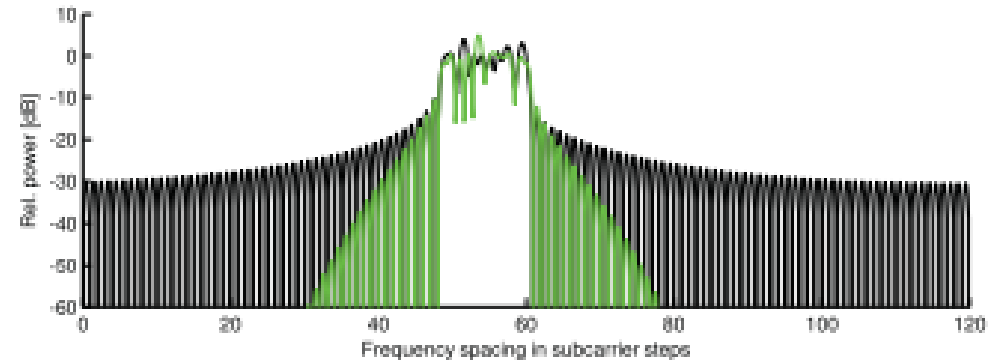
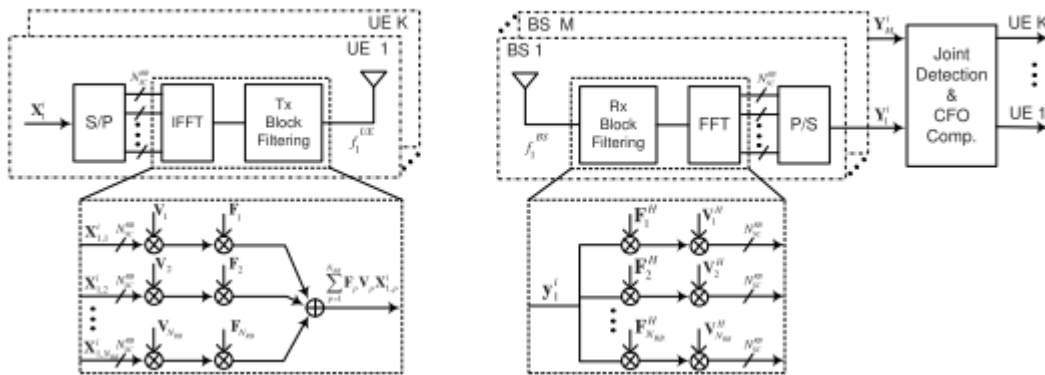

Vakilian, *5GNOW: Non-Orthogonal, Asynchronous Waveforms for Future Mobile Applications*, Globecom 2013

GFDM (Generalized Freq. Div. Multiplexing)

- Block-based approach
 - One cyclic prefix per block of symbols
- Tail-biting (circular) filtering for reduced filter overhead

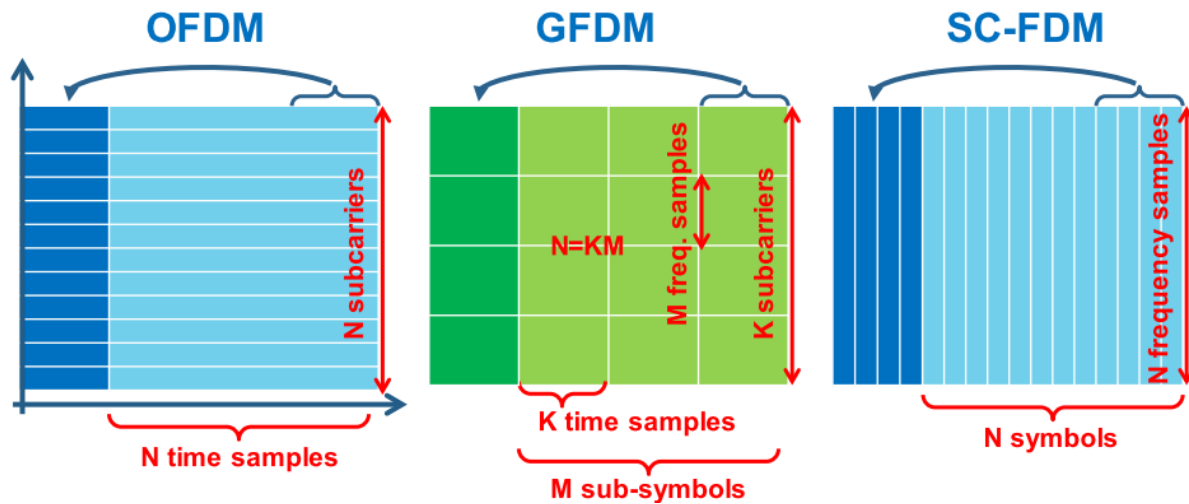

Fettweis, *Designing A Possible 5G PHY With GFDM*, 5G Workshop, Globecom 2014

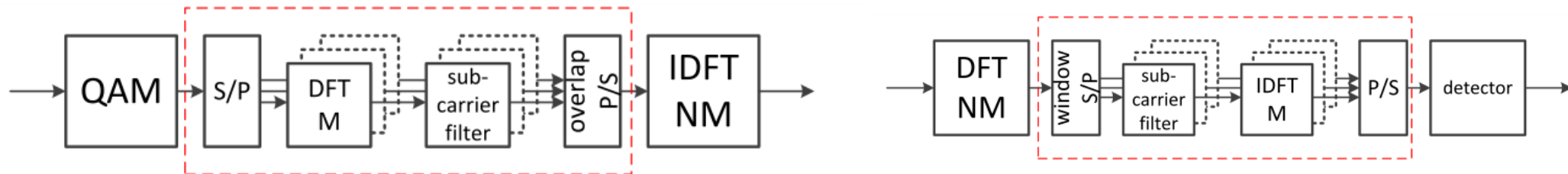

ZT-DS-OFDM (Zero-Tail DFT-Spread OFDM)

- Similar to DS-OFDM (SC-FDMA)
 - With zero-tail instead of cyclic prefix
 - ZT inside FFT length
 - ✓ Different users may have different guard intervals
 - Low-power head guarantees low out-of-band radiation

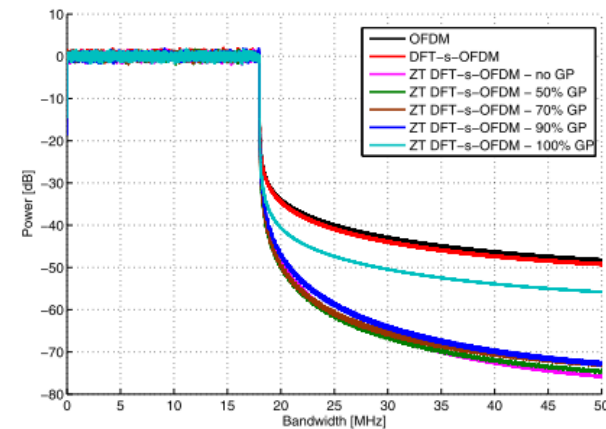
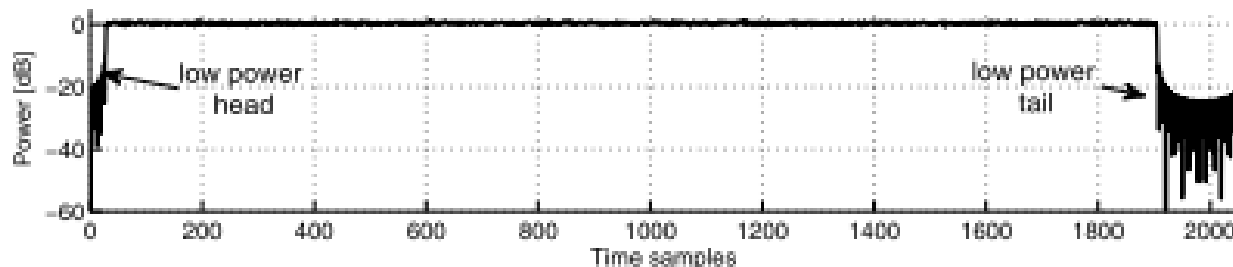

Faster-than-Nyquist

- Nyquist criterion for zero inter-symbol interference

$$\sum_{i=-\infty}^{\infty} P\left(f - \frac{i}{T_s}\right)$$

- Lowest bandwidth can be achieved with `sinc` pulses,
✓ $B = R_s$ (*roll-off* = 0)

- Lower bandwidth can be achieved if ISI is allowed

- Partial-response signals
✓ May be done in time and frequency
- Capacity increases

$$C_{\text{PSD}} = \int_0^{\infty} \log_2 \left[1 + \frac{2P}{N_0} |H(f)|^2 \right] df \text{ b/s.}$$

- But equalization / interference cancellation is needed

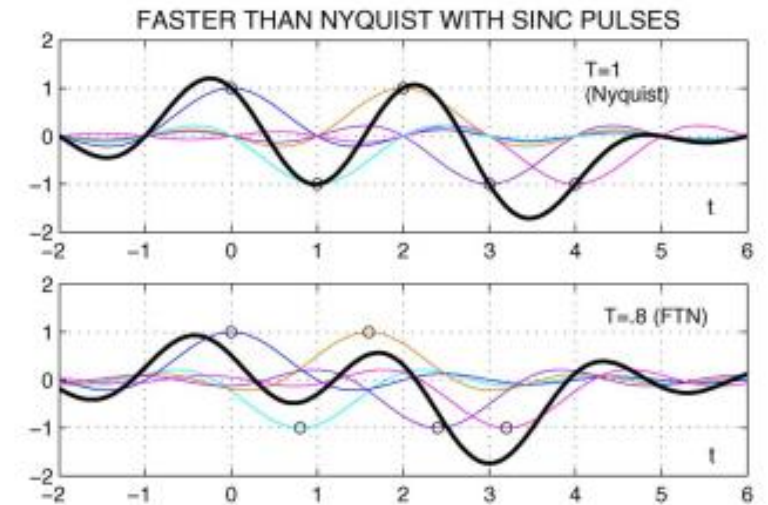

Anderson, *Faster-Than-Nyquist Signaling*,
Proc. of the IEEE, 2013

Or OFDM???

- It still not clear whether we really need to abandon OFDM
 - Orthogonality makes MIMO easier...
- Complexity of other techniques is (much) higher
 - This can be a particularly important issue in 5G
 - ✓ Very large bandwidths (>200MHz) , consequently large number of subcarriers
 - ✓ Cheap and energy-efficient devices are needed for IoT
 - ✓ But, on the other hand, Moore's law is still valid (but for how long?)

Higher-Order Modulation Schemes

- High data rates and high spectral efficiency require

- Multiple antennas
- Higher order modulation schemes

✓ 256 / 512 / 1024 – QAM

- RF imperfections like I-Q imbalance/phase noise may cause an unacceptable error floor
- Non-square / non-uniform constellations may be employed

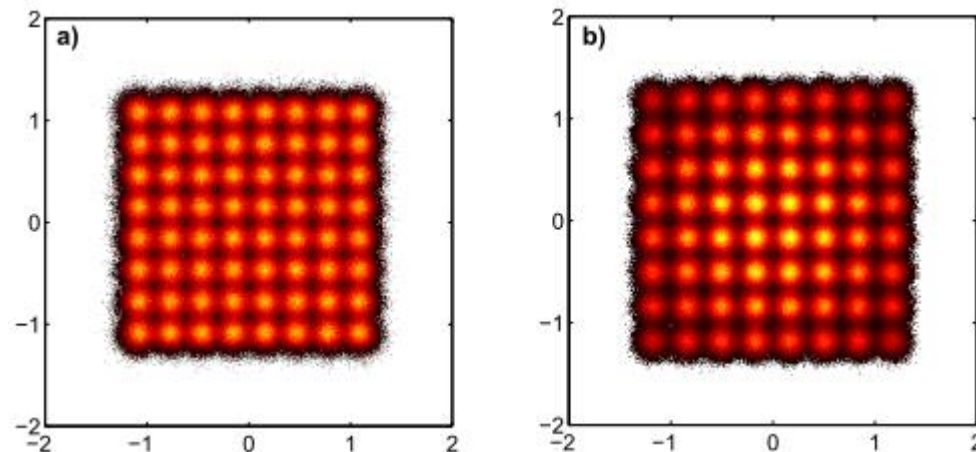

NOMA/SCMA

- Instead of the orthogonal multiple access from OFDMA
- NOMA (Non-Orthogonal Multiple Access)
 - Users are superposed in code and power domain
 - Requires interference cancellation at receiver
- SCMA (Sparse-Code Multiple Access)
 - Multiuser superposition coding using multidimensional codewords
 - Lower-complexity receiver algorithms are possible due to sparse codes
- Higher spectral efficiency

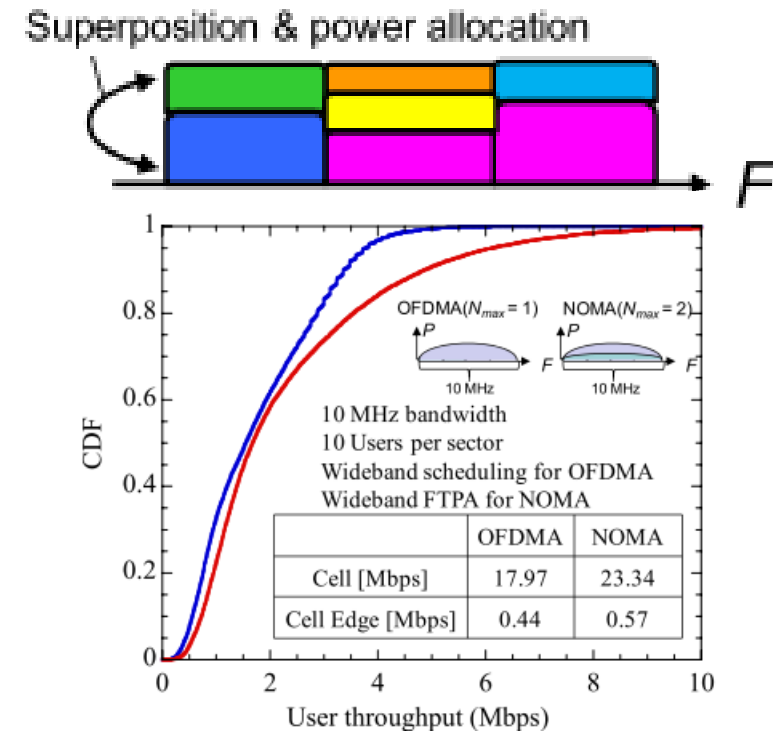

Saito, *Non-Orthogonal Multiple Access (NOMA) for Cellular Future Radio Access*
VTC-Spring, 2013

Error control in 4G

- Turbo and LDPC codes are known to get very close to the theoretical Shannon limit
 - Used in LTE (Turbo) and IEEE 802.11n/ac (LDPC)
- HARQ can further help achieve low BER with adaptive code rate
- Very low BER can be achieved by ARQ

Do we need new coding schemes?

- Very low BER ($<10^{-10}$) is needed for critical services
 - LDPC/turbo are very efficient for higher BERs, but have an error floor (depending on the code length)
- IoT may use short packets
 - But good codes (LDPC/turbo) usually require long codewords
- Low latency is one of the requirements in 5G
 - HARQ and ARQ cannot be applied in this case
- Energy-efficiency is also a requirement
 - But good iterative decoding algorithms are very power hungry
- Polar Codes have been recently suggested, achieving channel capacity
 - But practical implementations are still a long way

Network Codes

- Coding for a point-to-point link is a (nearly) closed issue
 - LDPC/Turbo/Polar codes
- But on a network level, many gains can still be (possibly) obtained
- Network Codes can bring about potential gains in multihop networks
 - Both at network-level (using binary operations) and PHY-level

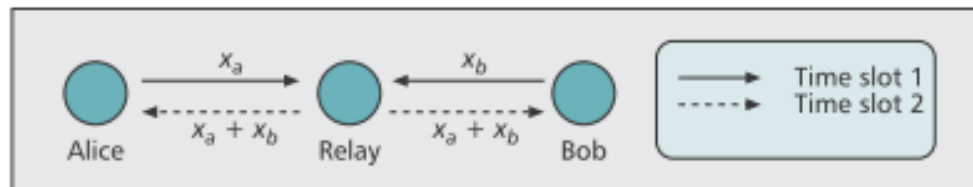

Fu et al., *COOPERATIVE WIRELESS NETWORKS BASED ON PHYSICAL LAYER NETWORK CODING*,
IEEE Wireless Communications, 2010

INTERFERENCE CONTROL



The interference Problem

“No man is an island ...” (John Donne – 17th century English Poet)

“... No CELL is either” (Telecom Engineer - 21st century)

- Interference is one big concern in cell network deployments.

The interference Problem

“No man is an island ...” (John Donne – 17th century English Poet)

“... No CELL is either” (Telecom Engineer - 21st century)

- Interference is one big concern in cell network deployments.
 - Since first generations, interference is a big problem degrading cell-edge performance.
 - ✓ Every cell is surrounded by other network cells
 - ✓ Inter Cell Interference
 - ✓ Reuse Factor

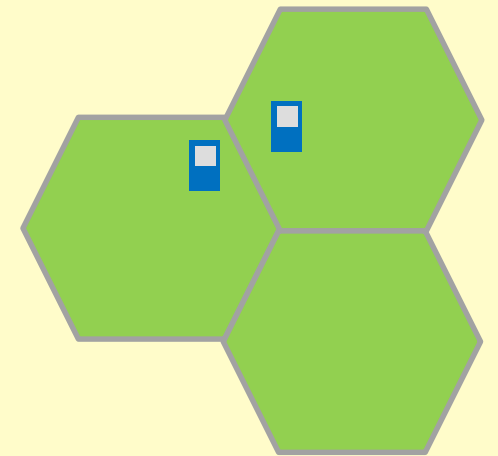

The interference Problem

“No man is an island ...” (John Donne – 17th century English Poet)

“... No CELL is either” (Telecom Engineer - 21st century)

- Interference is one big concern in cell network deployments.
 - Since first generations, interference is a big problem degrading cell-edge performance.
 - ✓ Every cell is surrounded by other network cells
 - ✓ Inter Cell Interference
 - ✓ Reuse Factor
- LTE was designed to reuse all available resources in all its cells (Reuse Factor = 1)
 - At first, LTE relied on fast UE feedback to cope with interference:
 - ✓ Adaptive Modulation and coding
 - ✓ HARQ
 - ✓ Fast Scheduling

But, with increased network traffic the interference problem has evolved too.

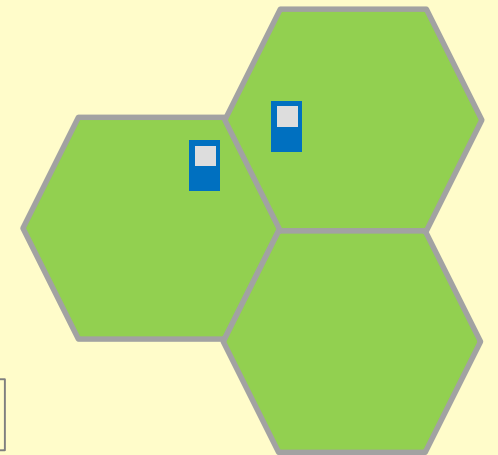

Interference Scenarios

- Increased Traffic. Densification. HetNets. Better Cell-Edge experience.
...but wait. There is no free lunch! See some examples:

Scenario 1

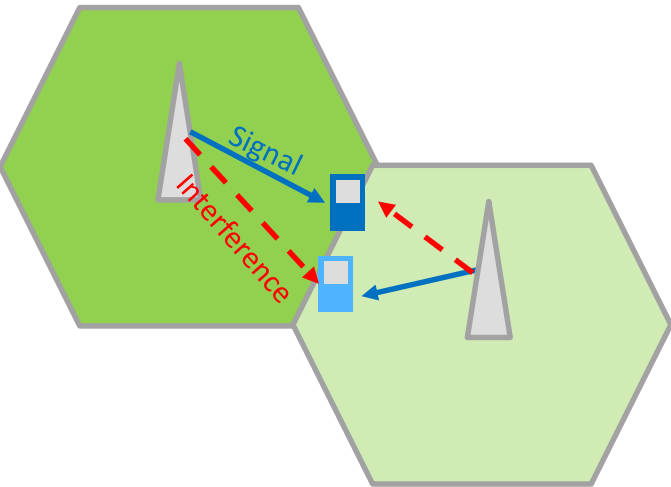

- Massive Traffic : Several Users
- High interference for cell edge users
- Low SINR
- Impact in throughput

Scenario 2

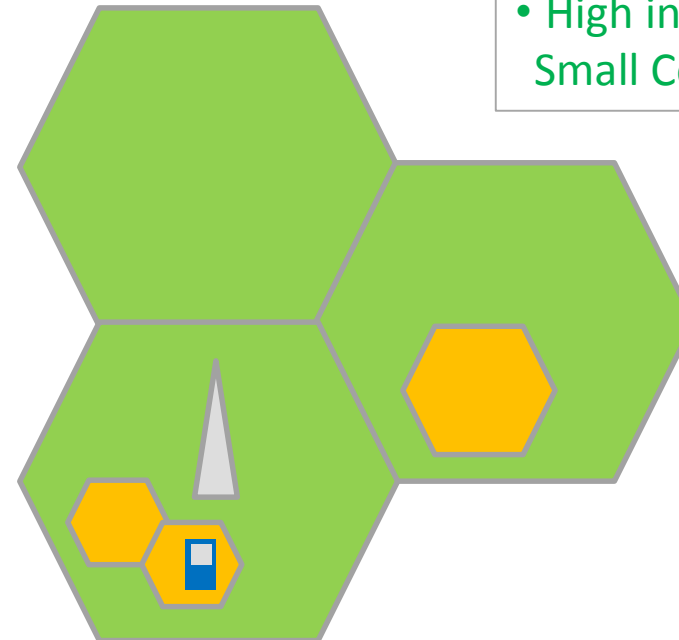

- Densification: HetNets
- Small Cells coexisting with Macro Cells
- High interference from Macro to Small Cell

ICIC

- LTE Release 8 presented ICIC (Inter-Cell interference Coordination)
 - ICIC Prevents neighbor cells of using same resources at cell edge to minimize interference.
 - Requires coordination between eNBs via X2 Interface.

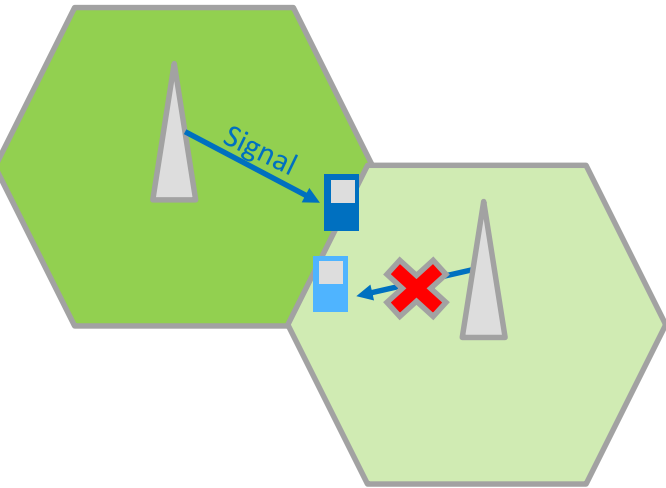

- Mutually Exclusive resource reservation for cell-edge users:

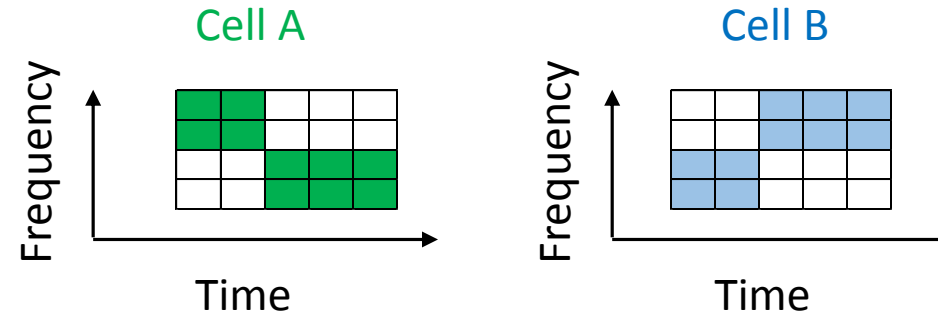

- Mid-cell users may reuse the same resources in different cells.

- It does not solve the problem for the HetNet Scenario.
- Reduced Cell Throughput

e-ICIC

- LTE Release 10 presented e-ICIC (enhanced ICIC)
 - Allows resource partitioning between macro and small cell.
 - ✓ Almost Blank Subframe (ABS)



Macro Cell does not send data traffic on ABS.

"Hey, small cell! I will relax a little. I won't bother you for now" (Macro Cell)

- HeNB is also expected to adjust its power to avoid interference to other cells
- **Reduced Cell Throughput**

COMP

- What if we USE the interference instead of trying to cancel it?

- COMP (Coordinated MultiPoint – Release 10)

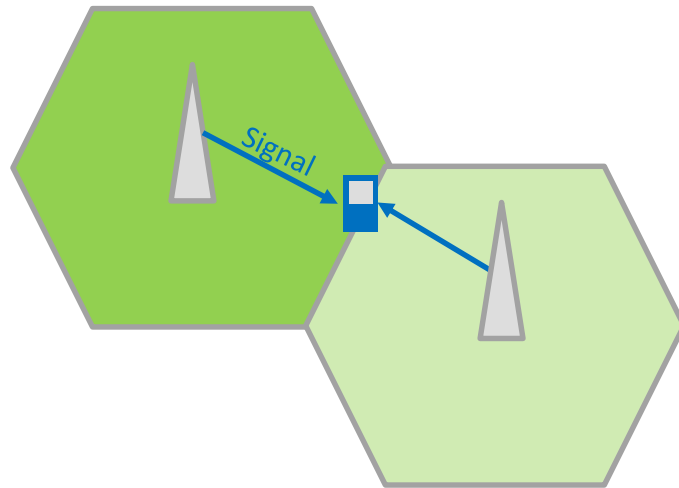

- Improve performance by using same resources at cell edge.
 - Joint Processing;
 - Beamforming;
 - COMP Reception (UL)
- Joint Processing:
 - Two cells transmit the SAME information
 - UE Combines the signals
 - Improved SINR
- Coordinated Scheduling and Beamforming (CS / CB)
 - Phase applied in the transmitted signal to make it directive
 - Allows resource reuse: different eNBs transmit in different beams
- COMP Reception:
 - Different eNBs receive UE signal
 - They combine the received signal
 - UE does not need to be aware of COMP

COMP

- COMP Requires Fast Coordination
 - Increased backhaul utilization
 - Scheduling has to be strictly coordinated between Cells:
 - ✓ But there is no RNC in LTE
 - ✓ One eNB will be the controlling eNodeB
 - Near zero delay required between the cells

5G Interference Control

- New network architectures: new interference scenarios.

5G Interference Control

- New network architectures: new interference scenarios.
 - Examples:

Dynamic TDD

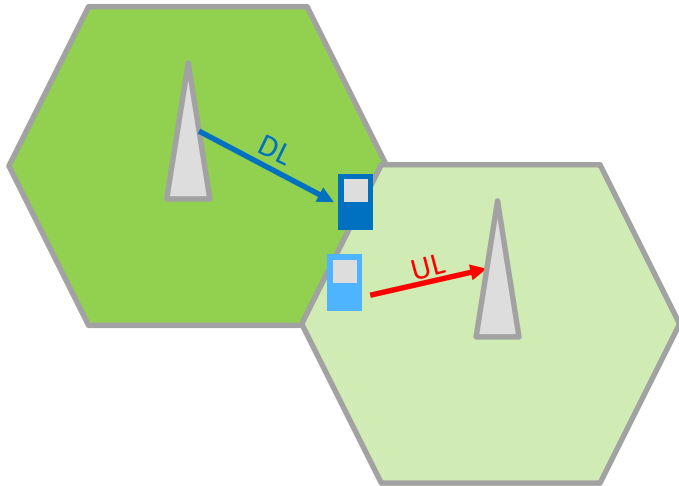

- Worst scenario: Cell Edge UE interferes by transmitting on a UE in the neighbor cell.

5G Interference Control

- New network architectures: new interference scenarios.
 - Examples:

Dynamic TDD

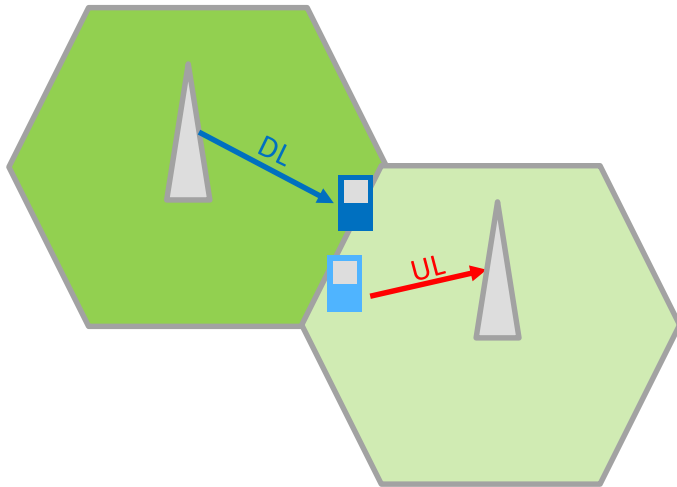

- Worst scenario: Cell Edge UE interferes by transmitting on a UE in the neighbor cell.

In-band Full Duplex



And they said I could not transmit and receive at the same time

Requires **SELF-INTERFERENCE** Cancellation

5G IC – Other Challenges

- Dynamic TDD or In Band Full Duplexing will increase dramatically the interference between DL/UL Users
 - It requires a robust coordination between the schedulers or;
 - More robust mechanisms to deal with the interference
 - ✓ PIC (Parallel-Interference Cancellation)
 - ✓ SIC (Sucessive-Interference Cancellation)
 - ✓ IRC (Interference Rejection Combining)

5G IC – Other Challenges

- Dynamic TDD or In Band Full Duplexing will increase dramatically the interference between DL/UL Users
 - It requires a robust coordination between the schedulers or;
 - More robust mechanisms to deal with the interference
 - ✓ PIC (Parallel-Interference Cancellation)
 - ✓ SIC (Successive-Interference Cancellation)
 - ✓ IRC (Interference Rejection Combining)
- Just remember: Low-latency is a 5G requirement!**
- ✓ Very Fast Interference estimation needed
 - ✓ Rapid data processing: Hardware requirements
 - ✓ Coordination?

Self Interference Cancellation

- In-band full duplexing may increase network capacity up to 2x
 - Self-Interference Cancellation
 - Operation principle similar to old telephones
 - ✓ Remove the TX signal replica from the Received signal
 - Frequency Agnostic Operation
 - ✓ Complexity scales linearly for carrier aggregation
 - ❖ But... it increases battery consumption (a lot ...)

Self Interference Cancellation

Uh! It seems simple. I know the tx signal! I just need to remove its version from the received signal.

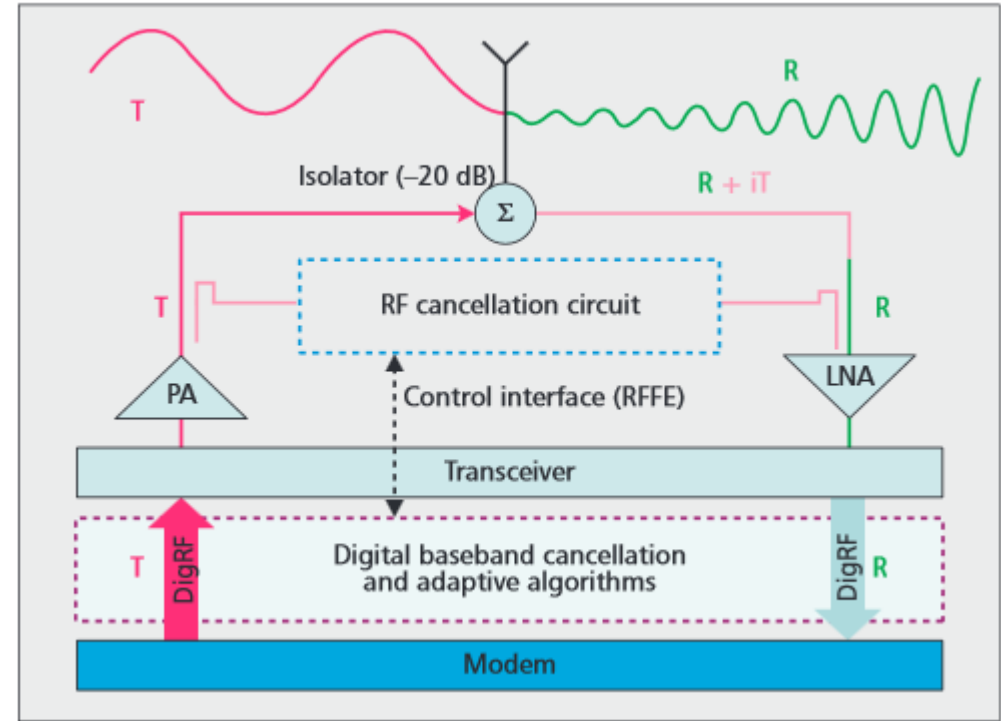

Extracted from:

http://cms.comsoc.org/SiteGen/Uploads/Public/Docs_TC_5GMWI/Applications_of_Self-Interference.pdf

Self Interference Cancellation

Uh! It seems simple. I know the tx signal! I just need to remove its version from the received signal.

But not so fast...

- The analog up-converted interfering signal is quite different of the known version:
 - Affected by non-linearities
 - ✓ Power Amplifier
 - ✓ Receiver Saturation
 - ✓ Phase Noise
 - ✓ ADC Resolution
 - Affected by time variation of Self-Interference Wireless Channel
- Interference power is many order of magnitudes stronger

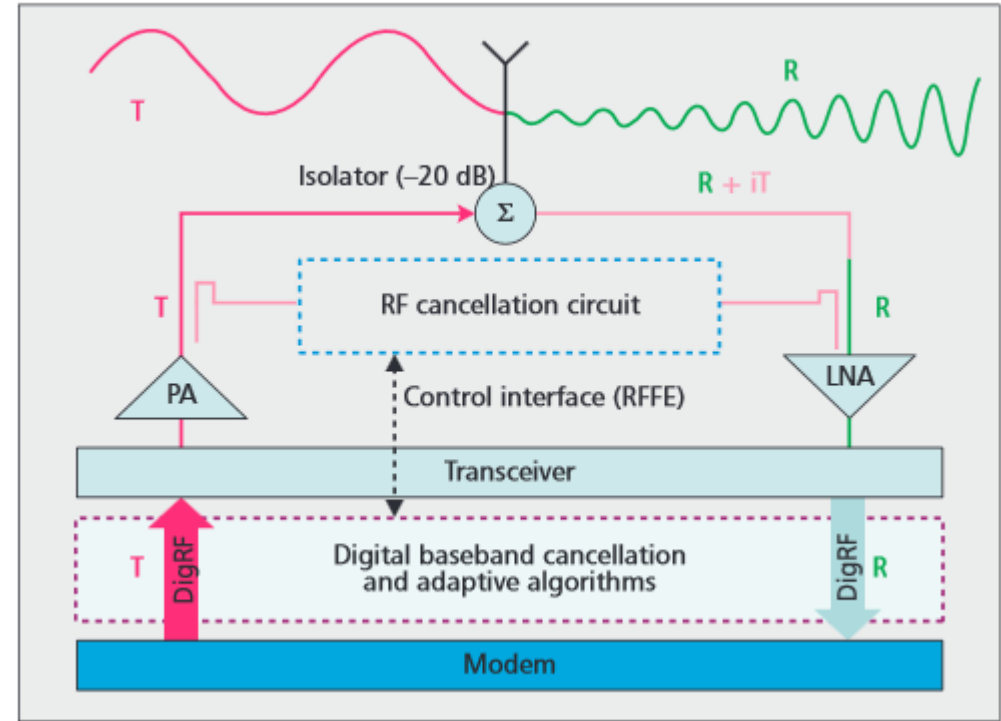

Extracted from:

http://cms.comsoc.org/SiteGen/Uploads/Public/Docs_TC_5GMWI/Applications_of_Self-Interference.pdf

The problem of synchronization

- There is an additional challenge for 5G Communication
 - **Synchronization!**
 - ✓ GPS is not a good approach to indoor environments
 - Distributed synchronization is needed
 - ✓ Sensors Network: Sensors may be dormant until they trigger a transmission.
 - ✓ Inaccuracy of Hardware Clocks
 - Synchronization problems may cause big interference problems.
 - ✓ It is necessary to develop a solution with a low response time to solve the synchronization problems

MASSIVE MIMO



Introduction

- MIMO system
 - **Increasing spectral efficiency** and **quality** with MIMO system opens a new dimension, **space**, offering high bit rates **without increasing transmitted power and bandwidth allocation**.
 - Information theory has shown that with **multipath propagation**, MIMO system can establish essentially **multiple parallel channels** that operate simultaneously, on the same frequency band at the same total radiated power.

MIMO System

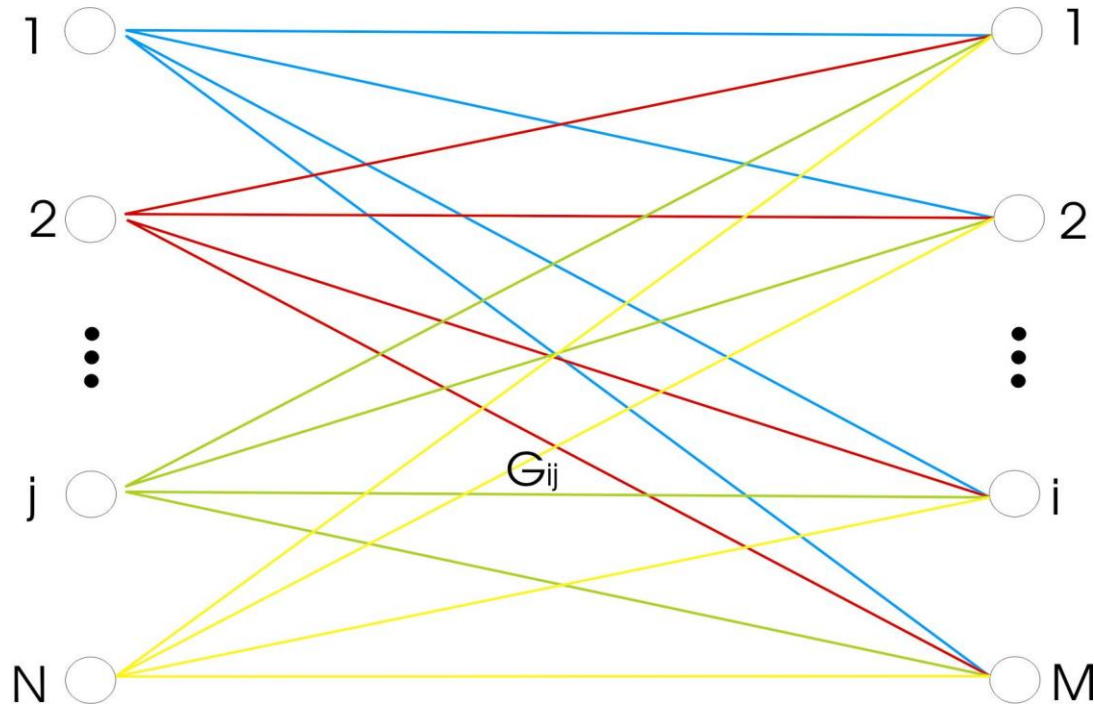

$$\{G_{ij}, i = 1, 2, \dots, M, j = 1, 2, \dots, N\}$$

- Diversity
- Adaptive Antennas
- Spatial Multiplexing

The central paradigm is **exploitation** rather than **mitigation** of **multipath** effects.

MIMO System

- Array gain: **increase coverage and QoS.**
- Diversity gain: **increase coverage and QoS.**
- Co-channel interference reduction: **increase cellular capacity.**
- Multiplexing gain: **increase spectral efficiency.**

Multi-antenna Schemes in LTE

- Receive diversity
 - User Equipment (UE) must support receive diversity
 - Base station (eNB) typically supports receive diversity
- Transmit diversity
 - DL: broadcast and control channels use transmit diversity
 - Space-Frequency Block Code (SFBC) is used –a version of the Alamouti scheme
- Beamforming
 - Used in data channels and enhanced control channels
 - ✓ Based on Channel State Information (CSI) feedback or channel reciprocity (in TDD))
 - 3D beamforming proposed in Rel 12
- Spatial multiplexing
 - Either closed loop (based on CSI feedback) or open loop
 - It has different spatial layers for a single user (SU-MIMO)
 - It has different spatial layers for multi-users (MU-MIMO)

What is Massive MIMO ?

- Other names
 - Large-Scale Antenna Systems
 - Very Large MIMO
 - Hyper MIMO
- M-MIMO is an array with **few hundreds antennas**
- Basic premise behind M-MIMO
 - Reap all the benefits of the conventional MIMO, but on a **much greater scale**
- M-Massive relies on **Spatial Multiplexing**
 - Extra antennas help by focusing energy into smaller regions of space to bring huge improvements in throughput and radiated energy efficiency



5G and Massive MIMO

- M-MIMO is one key **enabler for future Wireless Broadband** which will be
 - Energy Efficient,
 - Secure and
 - Robust
- M-MIMO is also an important enabler for the future digital society that will Connect **the Internet People and IoT with Clouds**.

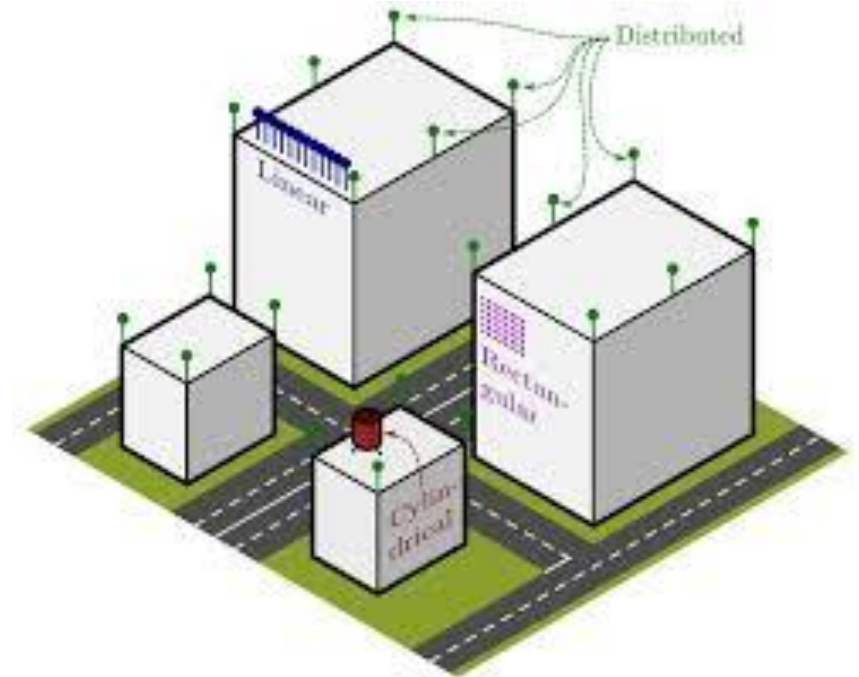

M-MIMO System

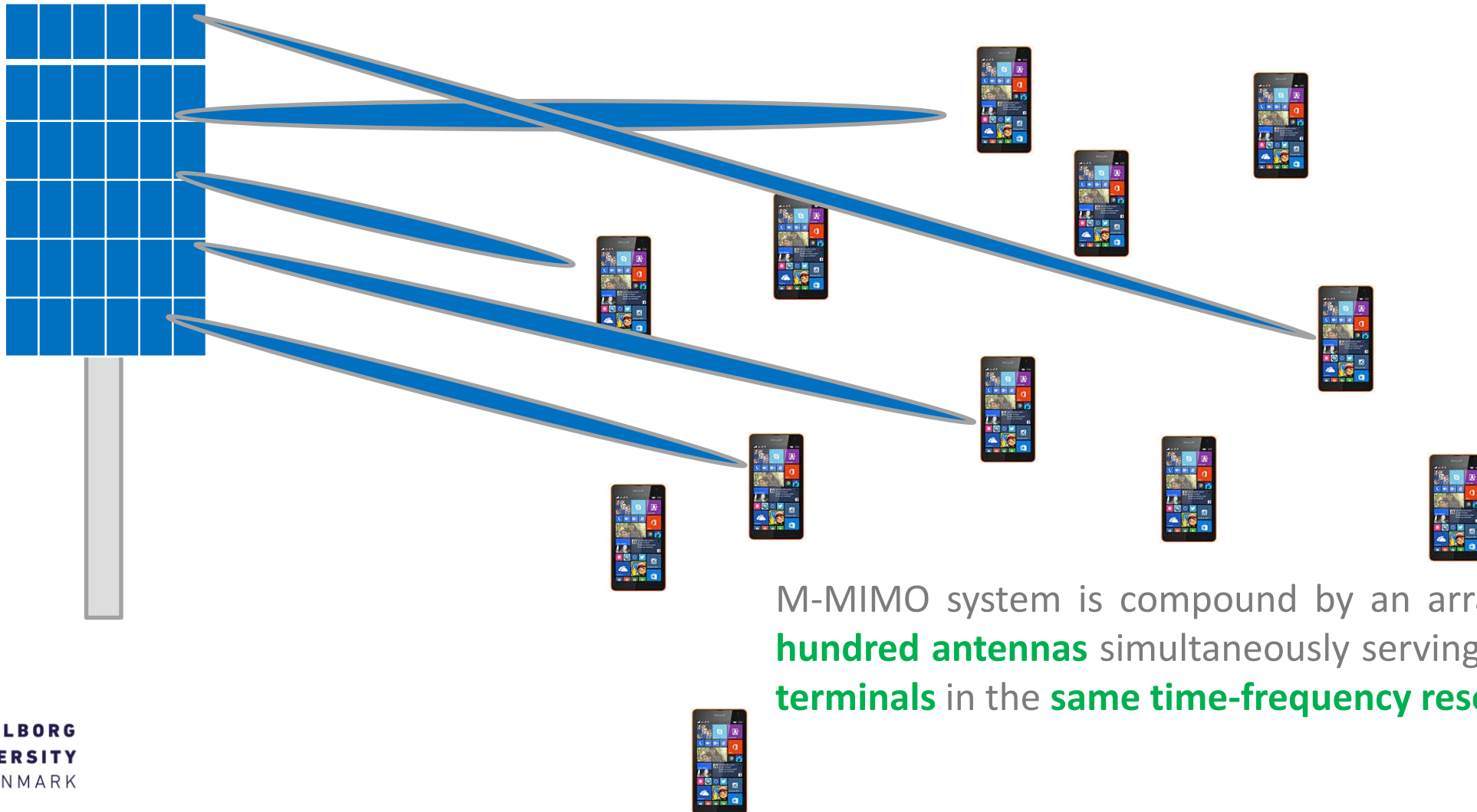

M-MIMO system is compound by an array with a **few hundred antennas** simultaneously serving **many tens of terminals** in the **same time-frequency resource**.

M-MIMO Benefits

■ M-MIMO can increase the capacity 10 times or more

- Capacity increase results from the aggressive spatial multiplexing
 - ✓ Energy can be focused with extreme sharpness into small regions
 - ✓ MmW requires directivity gain from large arrays to overcome high path loss and noise
- Large antenna arrays serving tens of users
- Simple signal processing becomes near-optimal with large arrays

■ M-MIMO improve the radiated energy efficiency on the order of 100 times

- Expensive ultra-linear 50 W amplifiers are replaced by hundreds of low cost amplifiers with output power in the milli-Watt range
- M-MIMO reduce the constraints on accuracy and linearity of each individual amplifier and RF chain

M-MIMO Benefits

■ M-MIMO simplifies the multiple access layer

- Since fading and noise become minor with large arrays, in OFDM system each subcarrier will have the same channel gain
- PHY and MAC control signaling redundant can be avoided.

■ M-MIMO enables to reduce of latency on the air interface

- Fading is one key issue to build low latency wireless link
- With M-MIMO
 - ✓ Fading and noise become minor with large arrays
 - ✓ Out-of-cell interference reduced due to directional transmission and blockage (in mmW)

Limiting Factors of M-MIMO

■ Channel Reciprocity

- TDD Operation relies on channel reciprocity
 - ✓ It is a consensus that the propagation channel itself is essentially reciprocal
- Problem
 - ✓ Hardware chains in the base station and terminal transceivers may not be reciprocal between the uplink and downlink
- Solution
 - ✓ Calibration of hardware chains

■ Pilot Contamination

- What is Pilot contamination?
 - ✓ There is a maximum number of orthogonal pilot sequences in a system.
 - ✓ The effect of reusing pilots from one cell to another and the associated negative consequences is termed pilot contamination.
- Problem
 - ✓ Channel estimates suffer “contamination” generated by the interference pilot
 - ✓ DL Beamforming generates an interference at those terminals that share the same pilot sequence
- Solution
 - ✓ Allocation of pilot waveform optimization
 - ✓ Clever channel estimation algorithms or blind techniques
 - ✓ New precoding techniques that take into account the pilot contamination



M-MIMO Research Problems

- Fast and Distributed Coherent Signal Processing
- Build Low Cost Hardware
- Hardware Impairments
- Channel Characterization
- HW Reciprocity Calibration
- Pilot Contamination
- Small Cell and Heterogeneous Design Solutions
- Prototype

SPECTRUM



4G Bandwidth

- LTE Predefined Bandwidths: Up to 20 MHz.

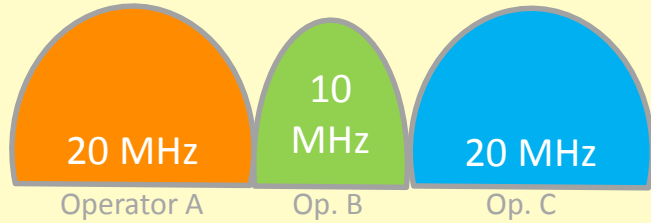

4G Bandwidth

- LTE Predefined Bandwidths: Up to 20 MHz.

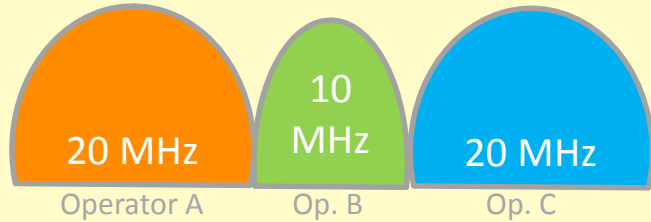

Uh-Oh! Physical Limitation:

Amount of information symbols that can be conveyed over a limited channel bandwidth.

- Shannon-Hartley Theorem

4G Bandwidth

- LTE Predefined Bandwidths: Up to 20 MHz.

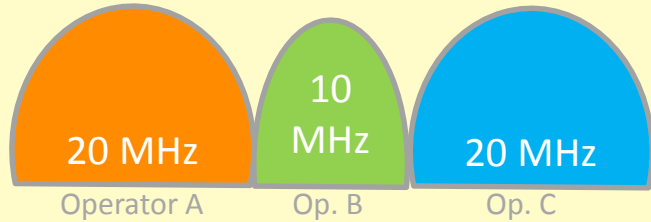

Uh-Oh! Physical Limitation:

Amount of information symbols that can be conveyed over a limited channel bandwidth.

- Shannon-Hartley Theorem

“ We need to scale up the amount of transmitted data! We need to increase the bandwidth ”

4G Bandwidth

- LTE Predefined Bandwidths: Up to 20 MHz.

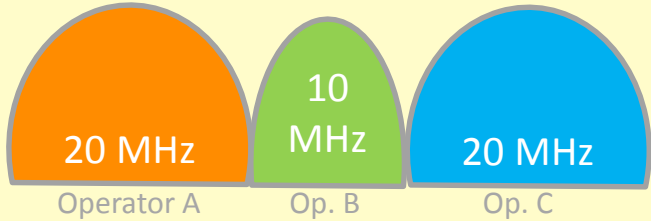

Uh-Oh! Physical Limitation:

Amount of information symbols that can be conveyed over a limited channel bandwidth.

- Shannon-Hartley Theorem

“ We need to scale up the amount of transmitted data! We need to increase the bandwidth ”

What if we aggregate the operator's bands?

4G Bandwidth

- LTE Predefined Bandwidths: Up to 20 MHz.

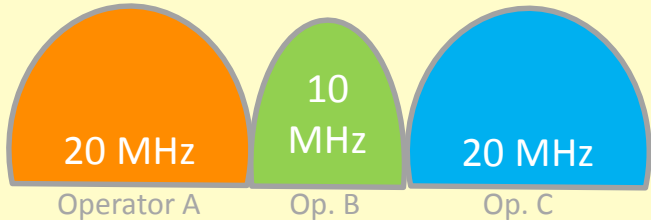

Uh-Oh! Physical Limitation:

Amount of information symbols that can be conveyed over a limited channel bandwidth.

- Shannon-Hartley Theorem

*“ We need to scale up the amount of transmitted data! We need to **increase** the bandwidth ”*

What if we aggregate the operator's bands?

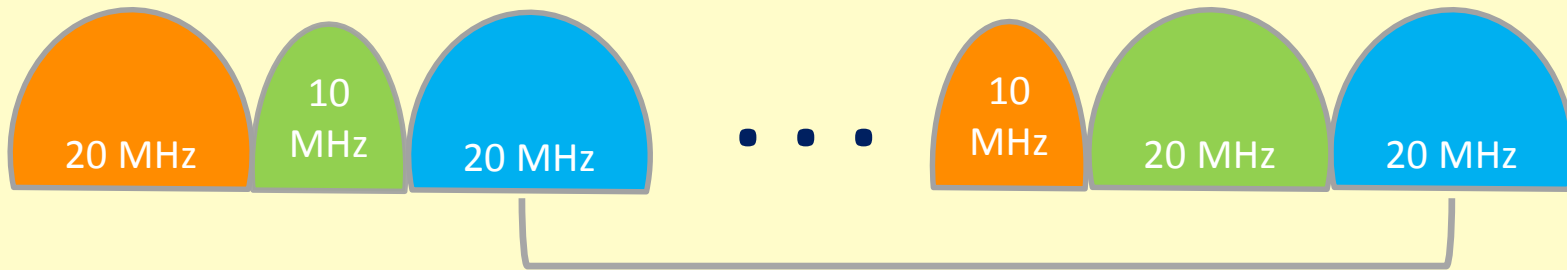

Operator C may aggregate its two bands to create a 40 MHz Bandwidth.

4G Bandwidth

- There are different types of Carrier Aggregation

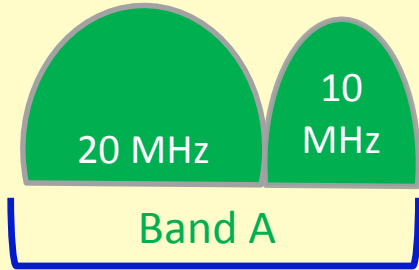

1. Intra-band Contiguous

4G Bandwidth

- There are different types of Carrier Aggregation

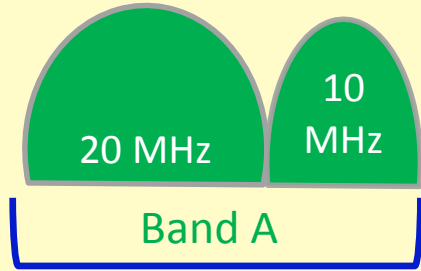

1. Intraband Contiguous



2. Intraband Non-Contiguous

4G Bandwidth

- There are different types of Carrier Aggregation

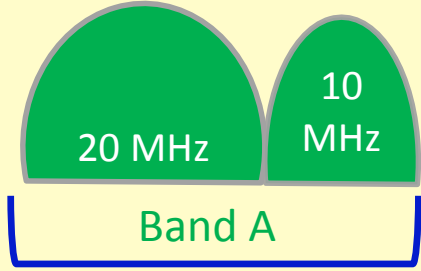

1. Intraband Contiguous

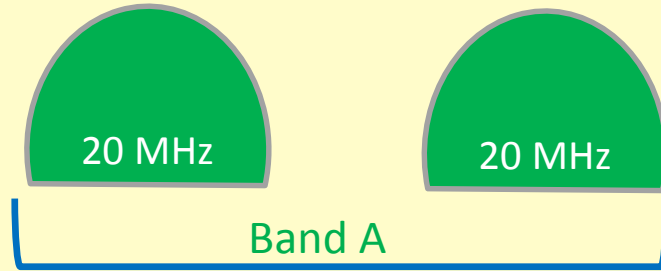

2. Intraband Non-Contiguous

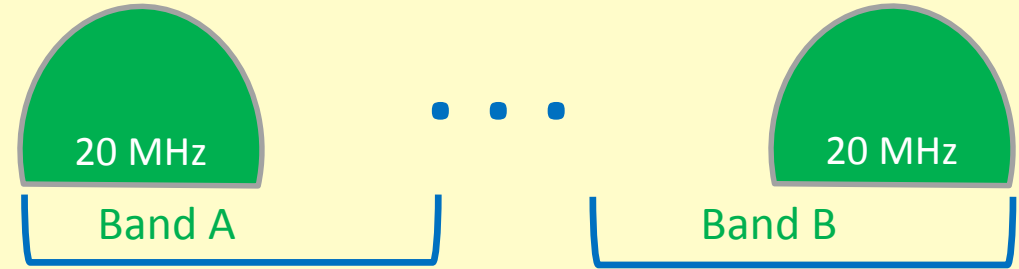

3. Interband Non-Contiguous

4G Bandwidth

- There are different types of Carrier Aggregation

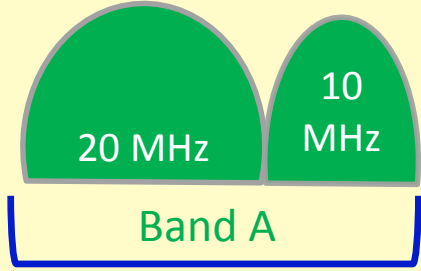

1. Intraband Contiguous



2. Intraband Non-Contiguous

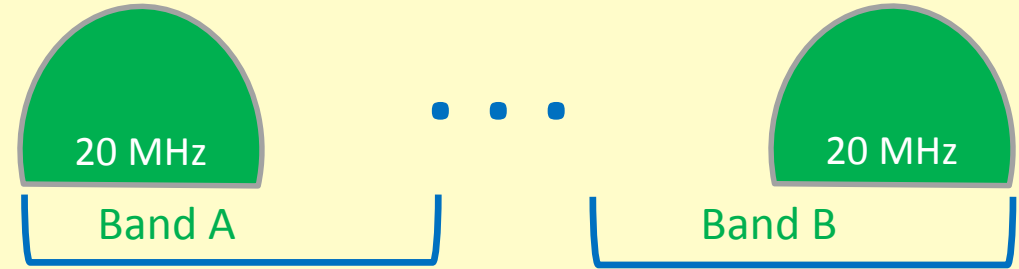

3. Interband Non-Contiguous

- 3GPP has planned CA with up to 5 Carriers.
 - The number of carriers does not need to be the same in DL/UL

4G Bandwidth

- There are different types of Carrier Aggregation

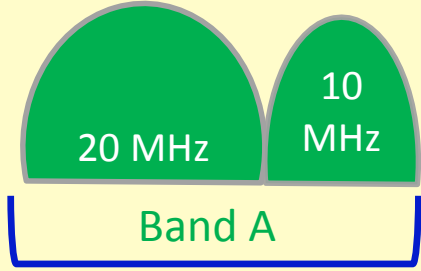

1. Intraband Contiguous



2. Intraband Non-Contiguous

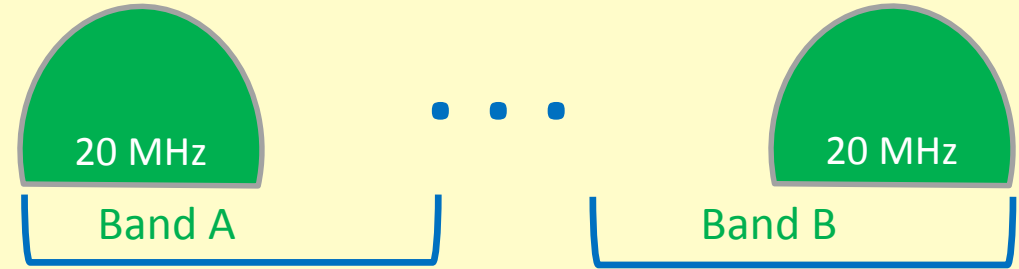

3. Interband Non-Contiguous

- 3GPP has planned CA with up to 5 Carriers.
 - The number of carriers does not need to be the same in DL/UL

$$5 \times 20 = 100 \text{ MHz}$$

Maximum Bandwidth

4G Bandwidth

- There are different types of Carrier Aggregation



1. Intraband Contiguous

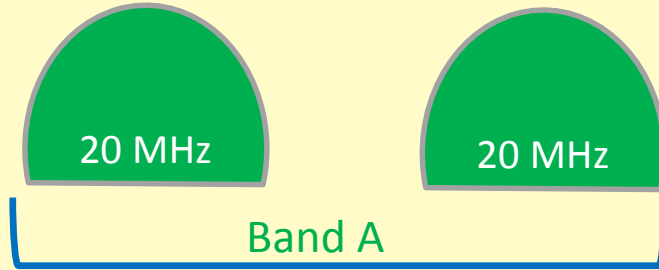

2. Intraband Non-Contiguous

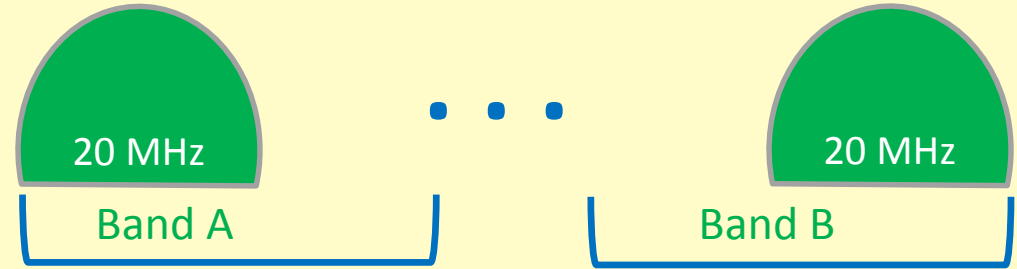

3. Interband Non-Contiguous

- 3GPP has planned CA with up to 5 Carriers.
 - The number of carriers does not need to be the same in DL/UL

$$5 \times 20 = 100 \text{ MHz}$$

Maximum Bandwidth

Problem Solved?

4G Bandwidth

Problem Solved?

- Not really. There are complications.
 - Radios do not support all band combinations yet
 - ✓ Band Combinations are being standardized by 3GPP.
 - Intermodulation
 - Limited Cellular Spectrum disputed by several operators
 - ✓ LAA: Licensed Access Assisted.
 - ✓ LTE users may compete for unlicensed bands: Wi-Fi Competition.

Carrier Aggregation Evolution



3GPP Release 10

- DL Intra Band Contiguous
- DL Interband
- Maximum 2 DL CA

3GPP Release 11

- DL Intra Band Non Contiguous

3GPP Release 12

- 3 Downlink CA
- 2 Uplink CA
- FDD+TDD
- Dual Connectivity

Beyond Release 12

- LAA
- Four DL CA

***WE NEED ANOTHER SOLUTION:
SEEK EMPTY PORTIONS OF THE SPECTRUM...***

mmWave and cmWave

cm/mmWaves

- Available UHF Cellular Spectrum is around: 600MHz.
 - Several ongoing initiatives to optimize its usage
 - Spectrum refarming
 - Cognitive Concepts (TVWS, ASA, LSA)
 - But still not enough
 - Spectrum is too crowded, difficult to maintain QoS
- cm/mmWave: a huge amount of spectrum
 - Much of it unused/underutilized
 - 3-30 GHz(cmWave)
 - 30-300GHz (mmWave)
 - Potential ranges: 28-30GHz, 60GHz, 81-86GHz and 92-95GHz
 - Spectrum Policy needed

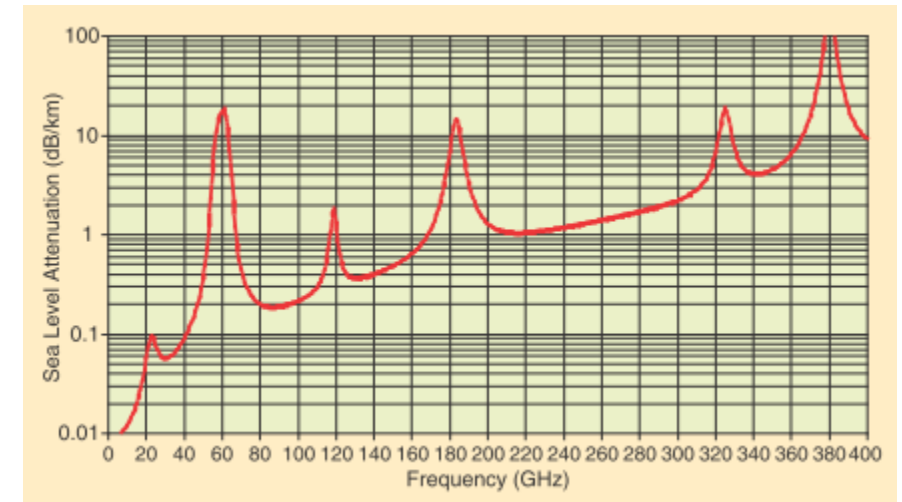





Wells, *Faster than fiber: The future of multi-G/s*,
IEEE Microwave Mag., 2009

Radio Propagation Considerations

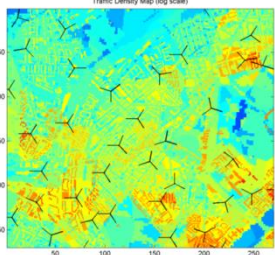
- Radio Propagation is the **key factor** in all the wireless systems.
- Mobile HetNets + new 5G scenarios + new Spectrum (cmwave & mmwave frequency bands) are relatively unexplored.
- Radio channel measurements and **modeling are still necessary** (and more important than ever) due to the new scenarios, the new frequency constraints and the future antenna designs (large arrays and massive MIMO).
- Many different measurement activities and contributions around the world towards an **unified 5G channel model**.

HetNets (from a Radio Propagation Perspective)

 	<p>Macro: BS antenna deployed in elevated positions above rooftop level. Propagation above rooftop + <u>diffraction</u> from rooftop to street level.</p>	<p>Low frequency bands < 3 GHz for overall coverage and mobility</p>
 	<p>Outdoor Small Cell (Micro): BS antenna deployed below rooftops close to street level (e.g. lamppost). Street canyon guiding (multiple <u>reflections</u> over the buildings) + diffraction on corners.</p>	<p>Co-channel with Macro < 3 GHz Or dedicated spectrum: 3.5 & 5 GHz</p>
 	<p>Indoor Small Cell (Femto): indoor BS deployment. Very complex indoor propagation: reflections, diffraction, multi-wall <u>transmission</u>,... * WiFi APs are also Indoor Small Cells... ... from a radio propagation perspective 😊</p>	<p>Coverage holes and capacity hotspots!</p>

Main propagation mechanisms vary with the type of cell and the frequency of operation!

What happens with Outdoor-to-Indoor?

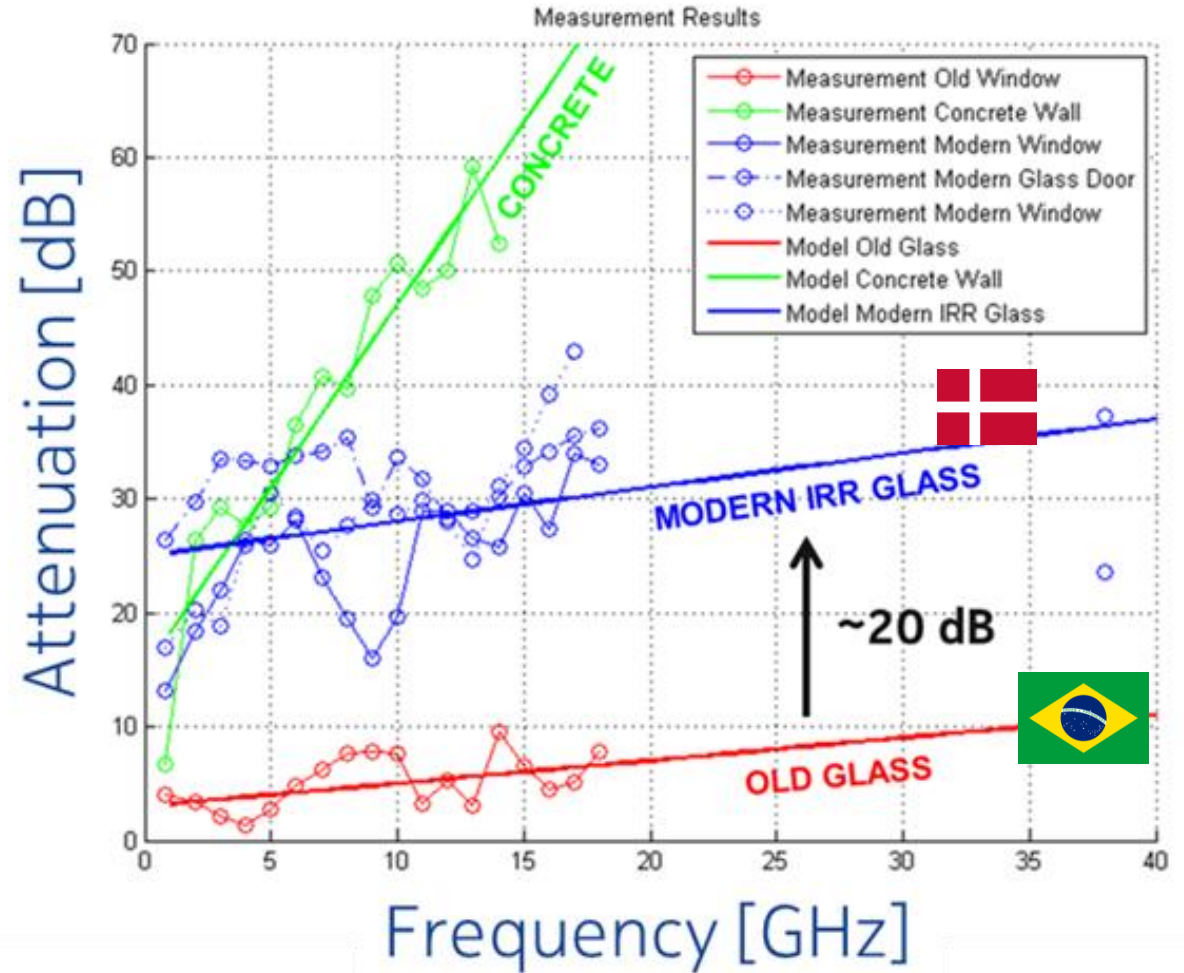
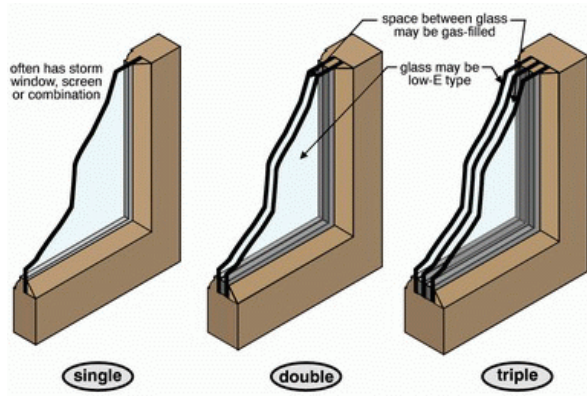
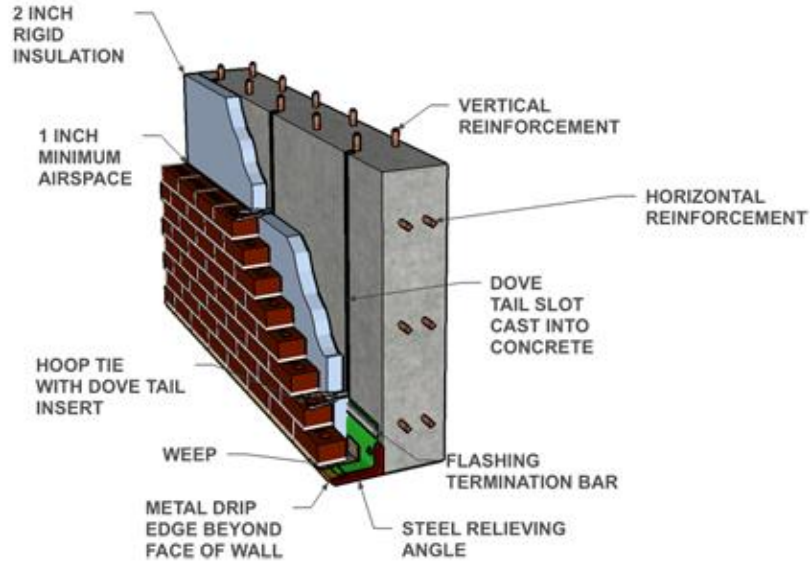

Big impact in outdoor-to-indoor coverage in cold countries, where good thermal isolation is necessary

New 5G Scenarios

- Telemedicine:
 - BAN (Body Area Network) for wireless sensors: movement detection, human shadowing.
- Vehicular scenarios:
 - V2V & I2V/V2I
 - HS (high speed)

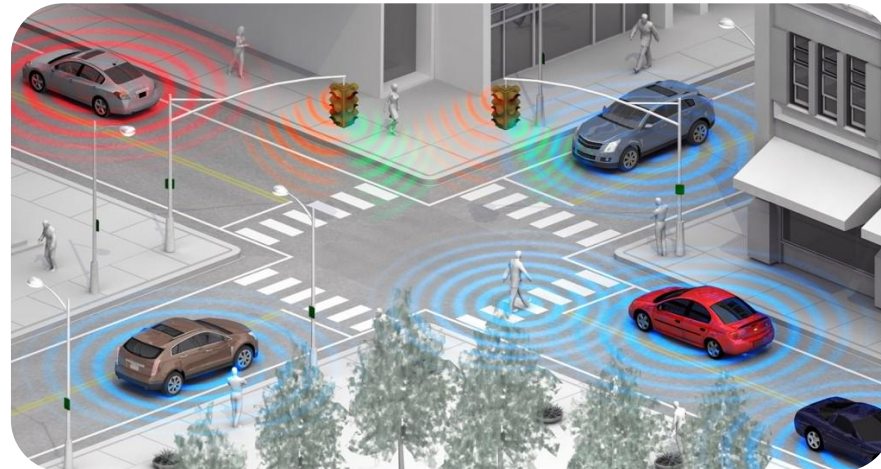
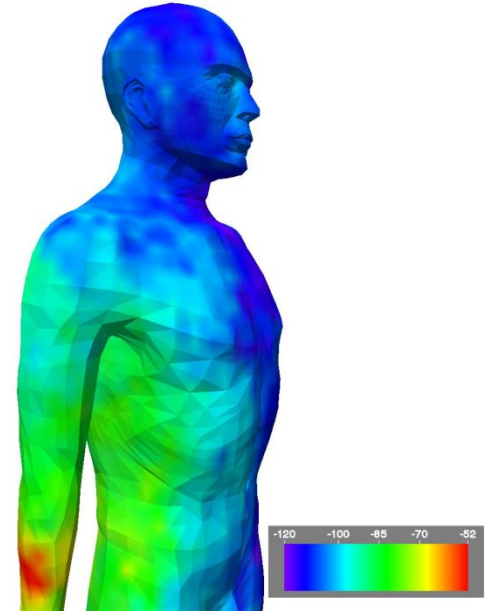
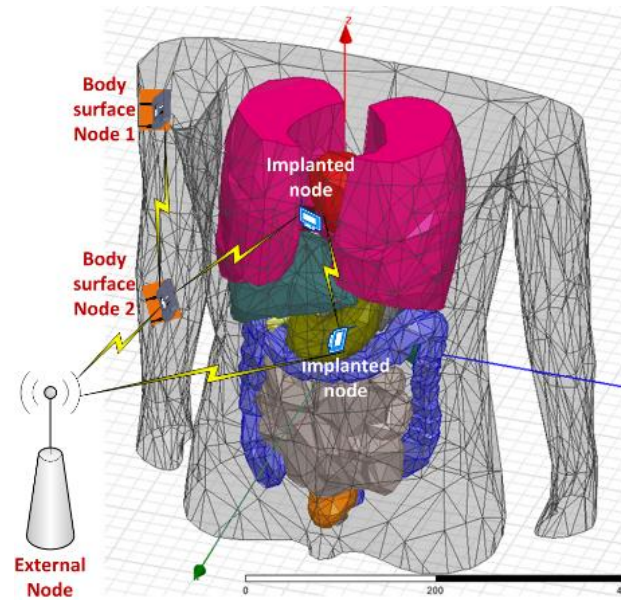

Propagation is quite unexplored in these scenarios

Spectrum Requirements

- Typical spectrum used by an European operator (December 2014):
 - 2G: (2 x 9 MHz) @900 + (2 x 11.8 MHz) @1800 / ~ 40 MHz
 - 3G: (2 x 15 MHz)@2100 + (1 x 5 MHz)@1900 / 35 MHz
 - 4G: (2 x 20 MHz) @800 + (2 x 20 MHz) @2600 + (2 x 10 MHz)@1800 / 100 MHz

TOTAL BANDWIDTH ~ 175 MHz (“only”)

- Bandwidth matters!
- Traditional spectrum below 6 GHz is limited.

$$C = W \log_2 (1 + S/N)$$

More spectrum is needed for future RATs & applications
Refarming? GSM for M2M? We will see...

Spectrum Utilization

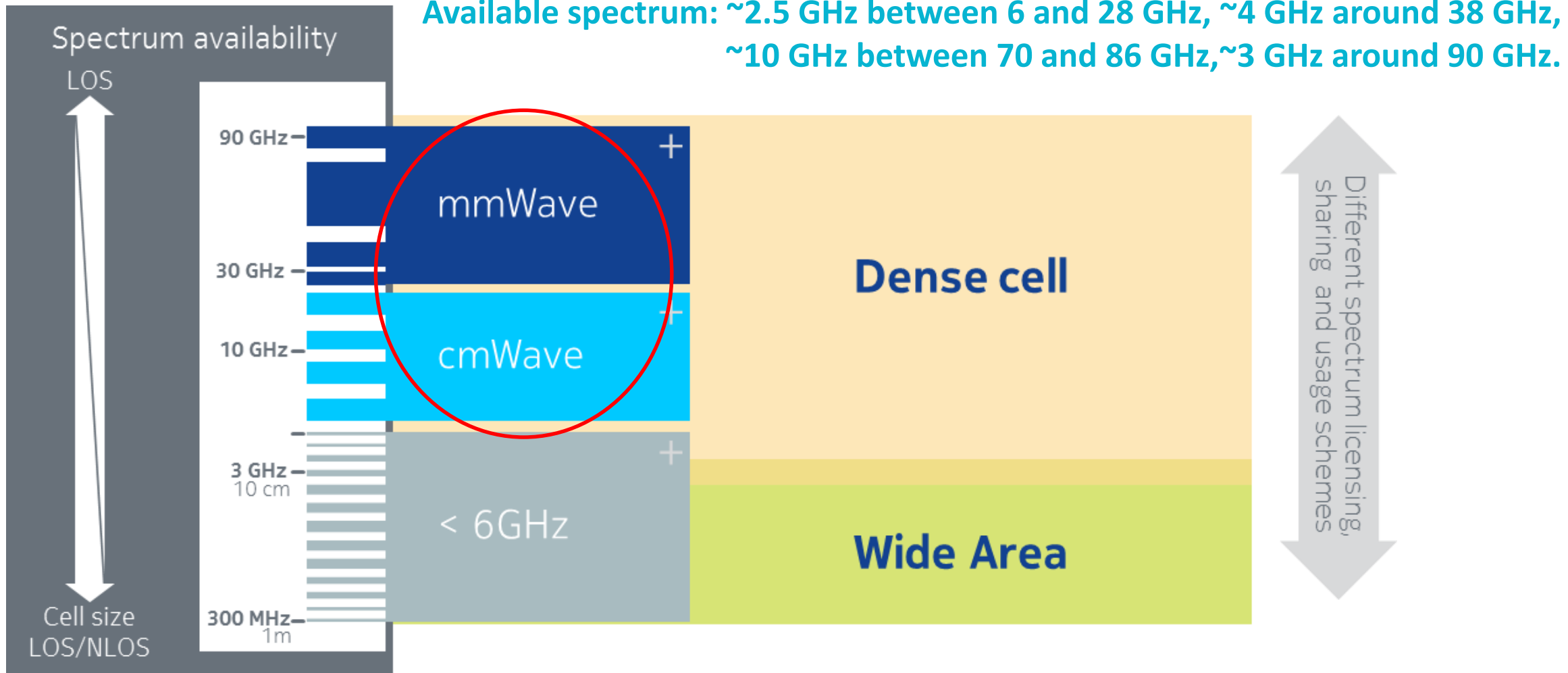

Large contiguous bandwidth opportunities!

5G Channel Modeling Activities

- There is a huge interest from **both industry and academia** in accurately characterizing radio propagation in frequency bands above 6 GHz.



- It is expected that interested groups are likely to collaborate in the future on developing a **unified channel model for 3GPP**.



5G Channel Modeling Requirements

- A unified/standardized 5G channel model is missing.
- Main requirements:
 - Spatial and temporal consistency (especially for non-stationary scenarios, with fast mobility).
 - Wideband characterization.
 - 3D extension (for both outdoor and indoor scenarios).
 - Should cover M2M scenarios.
 - Should be applicable in all frequency bands from low frequencies up to cmwave and mmwave.
 - Large antenna arrays and Massive MIMO.

“Old” Path Loss Modeling

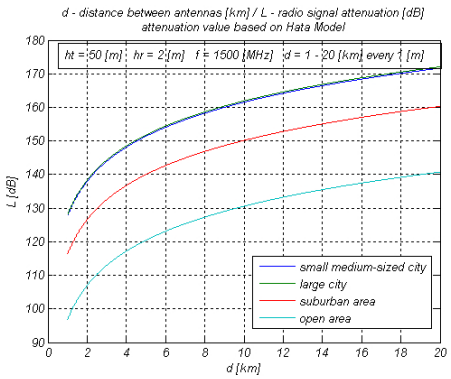

Empirical statistical: frequency, height & distance. Extensive measurement campaign needed in order to achieve statistical significance

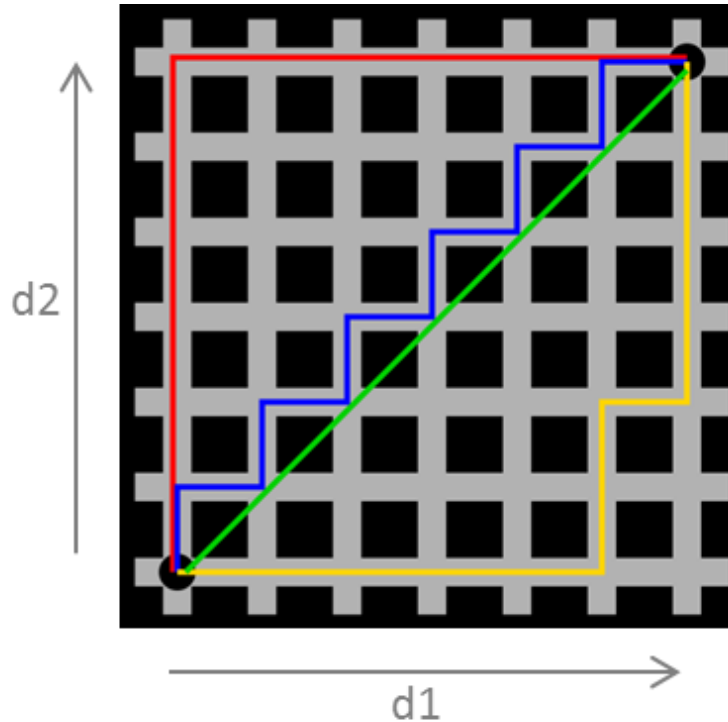

Semi-deterministic geometrical: frequency, height, distance & scenario distribution.

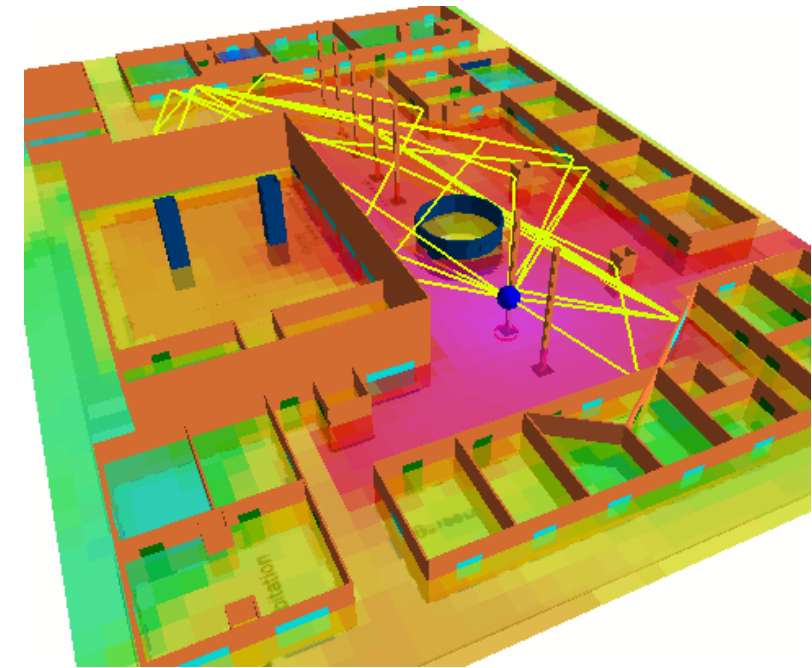

Fully deterministic (Ray-Tracing): height, distance, scenario distribution, electromagnetic properties,... (Not that big measurement campaign are required, but very accurate and time consuming)

+ level of detail/complexity/accuracy

Path Loss Modeling Approaches & Challenges

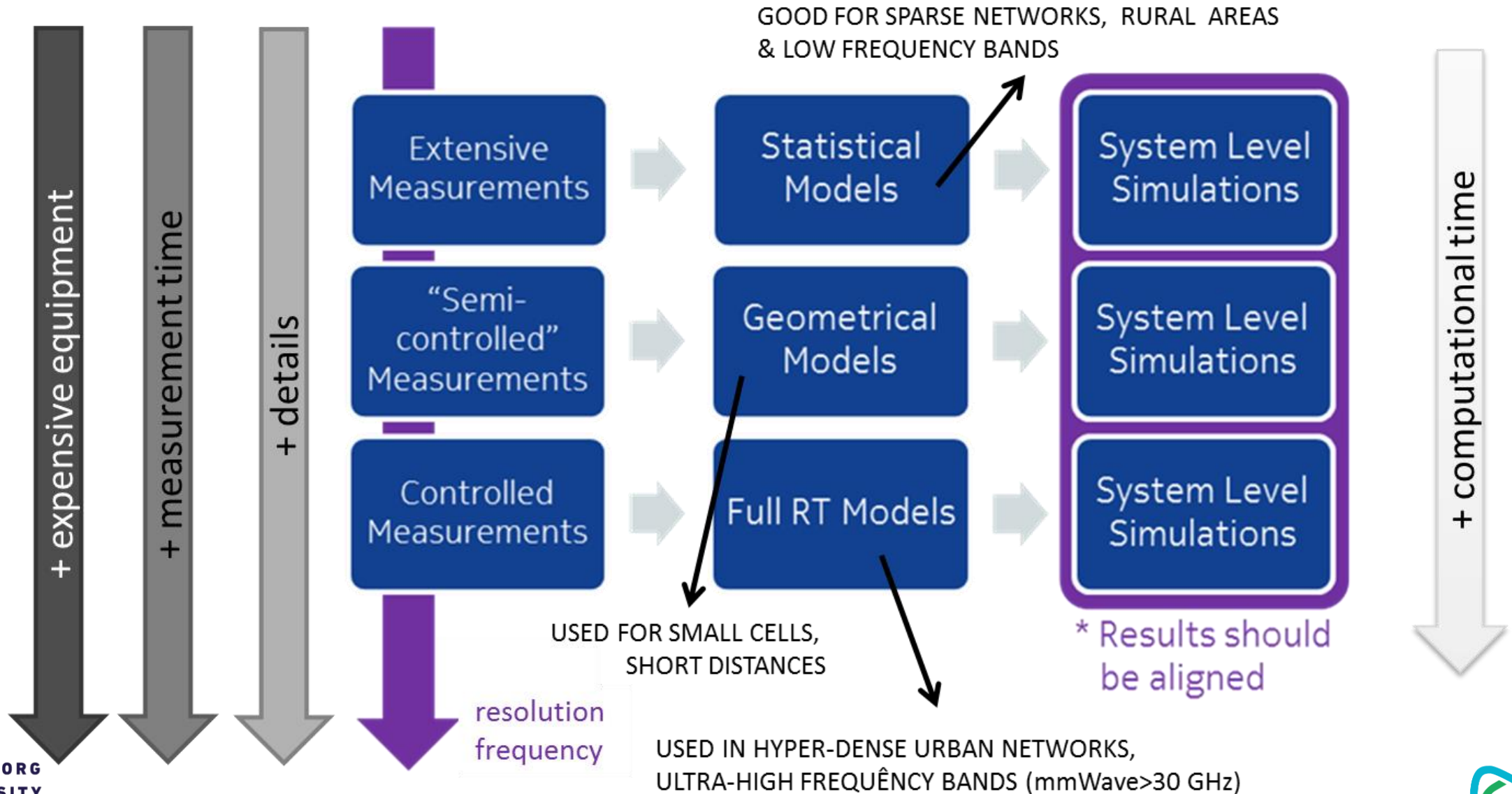

New “5G” Modeling Approaches

- Now is **more than path loss**. There is a need for directional 3D channel models for large array antennas (massive MIMO) and mmWave.
- The future is not “narrowband”. GHz bandwidths should be considered.
- New scenarios to be considered: M2M.
- A lot of **channel sounding** still needed.

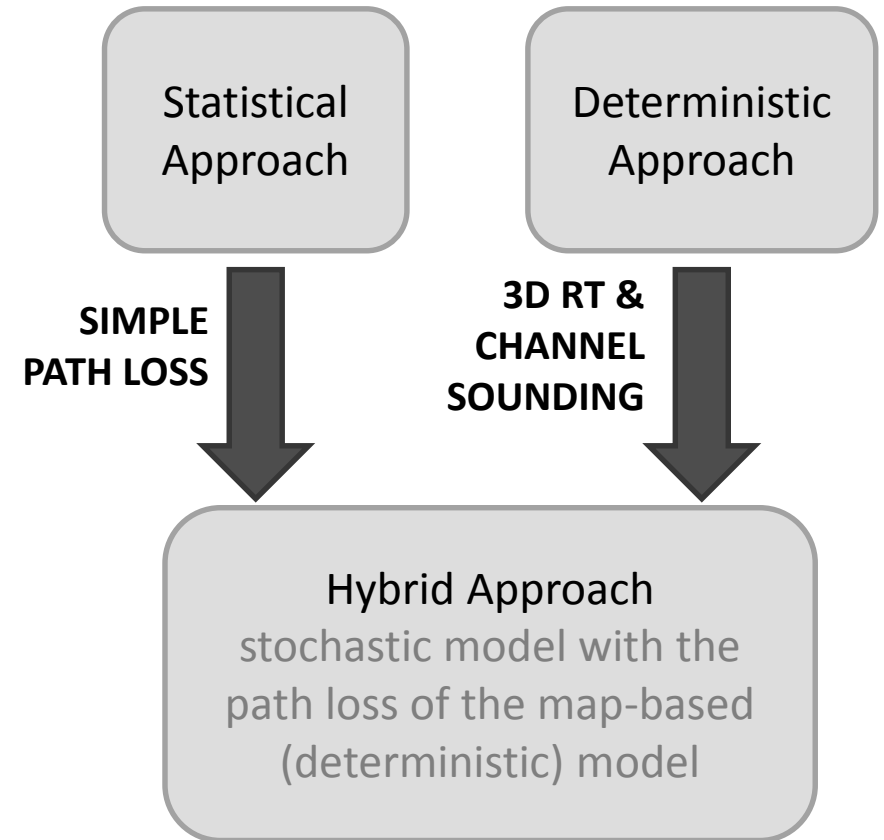

Standardized Models vs. METIS Objectives

Feature	3GPP SCM	WINNER II / WINNER+	IMT-Advanced	3GPP D2D	3GPP 3D	IEEE 802.11ad	METIS Model	
							stochastic	map-based
Frequency Range (GHz)	1 – 3	1 – 6	.45 – 6	1 – 4	1 – 4	60 – 66	up to 70 GHz	up to 100 GHz
Bandwidth (MHz)	5	100	100	100	100	2000	100 MHz < 6 GHz, 1 GHz @ 60 GHz	10 % of the centre frequency
Support massive-MIMO	no	limited	no	no	limited	yes	no	yes
Support spherical waves	no	no	no	no	no	no	no	yes
Support extremely large arrays beyond stationarity interval	no	no	no	no	no	no	no	yes
Support dual mobility	no	no	no	limited	no	no	limited	yes
Support Mesh networks	no	no	no	no	no	no	no	yes
Support 3D (elevation)	no	yes	no	no	yes	yes	yes	yes
Support mmW	no	no	no	no	no	yes	partly	yes
Dynamic modelling	no	very limited	no	no	no	limited	no	yes
Spatial consistency	no	no	no	no	no	no	SF only	yes

24 GHz Measurement Activities

- Characterization of the radio propagation at 24 GHz (cm-wave) in urban & suburban Brazilian-like scenarios:
 - Identification and characterization of dominant propagation mechanisms (diffraction, reflection, scattering, transmission).
 - Analysis of the number of “strong” received components for spatial diversity characterization.
 - Impact of vegetation.
 - Path loss analysis and modeling.



Directional Measurement Setup

- CW radio transmission at 24 GHz.
- Fixed TX rooftop antenna.
- Automated directional measurements at the RX side in order to characterize the received power in full azimuth (0-360 degrees) and +/- 30 degrees in elevation.

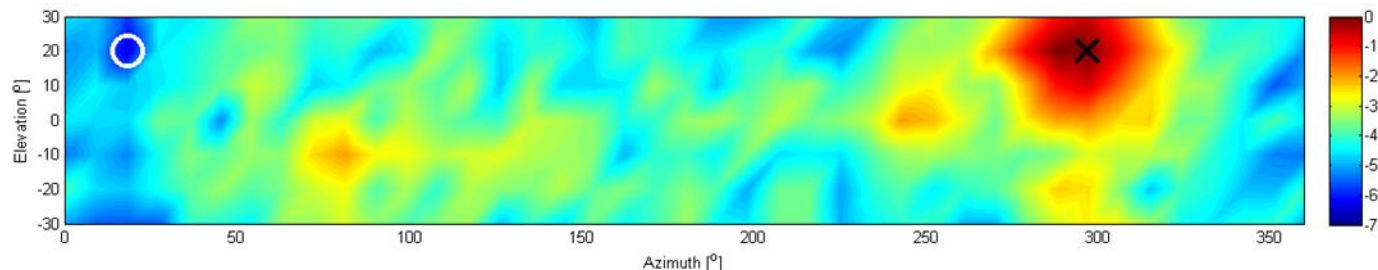

Some Preliminary Results

ABSOLUTE RECEIVED POWER

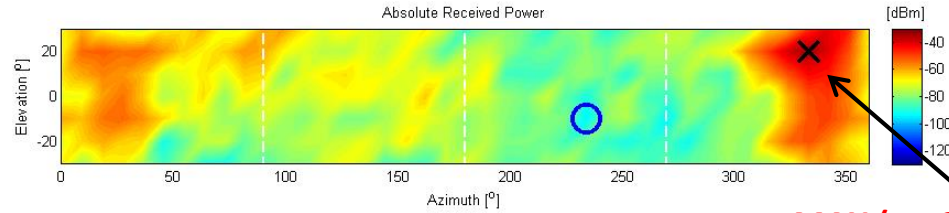

(az. 10-40, el. +20,-10)

MAX (az. 330, el. +20)

NORMALIZED RECEIVED POWER

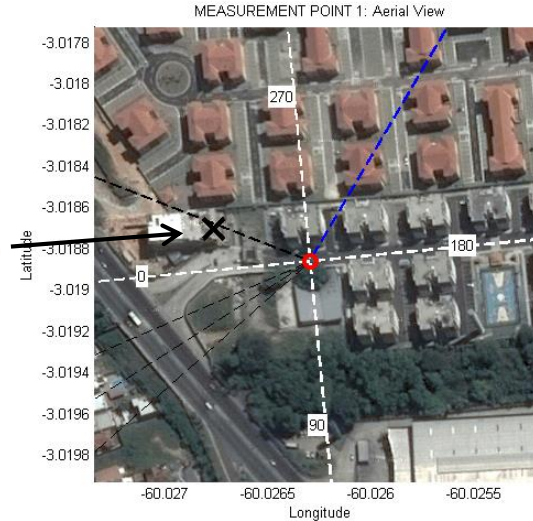
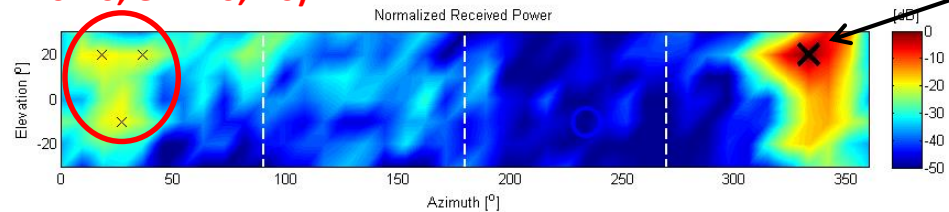

TOP VIEW WITH DIRECTIONAL INFORMATION (azimuth)

CDF ABSOLUTE RECEIVED POWER

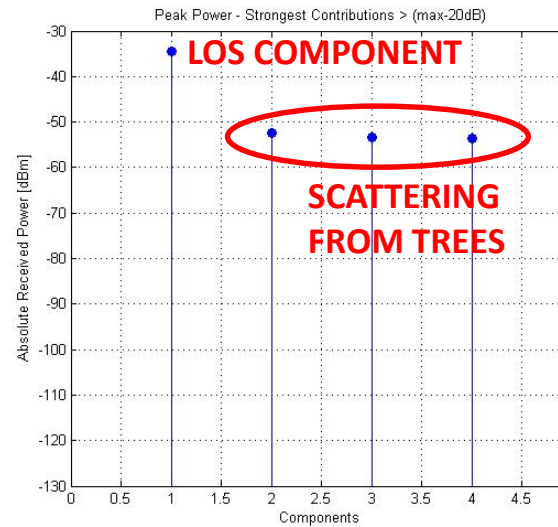
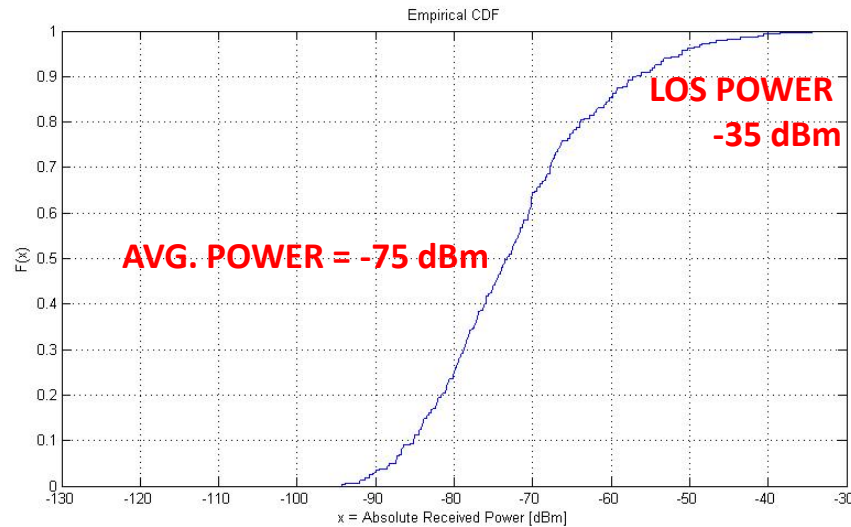

"STRONG" RECEIVED COMPONENTS

LOS position, 40 m distance to BS

MILLIMETER WAVE COMMUNICATION



mmWave + Massive MIMO

- Signal suffers very strong attenuation
- Massive MIMO and beamforming are key Technologies to increase range

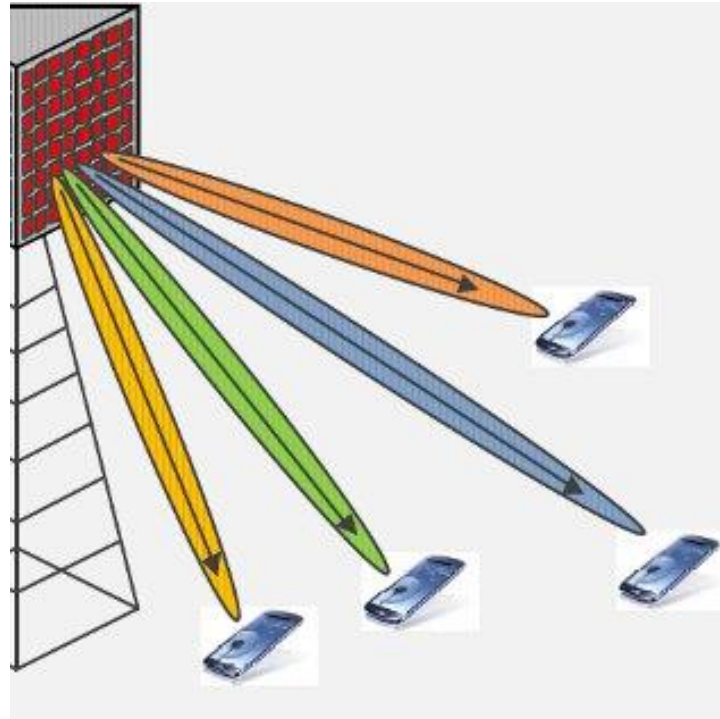

mmWave – MAC challenges

- New protocols are needed to manage the beam directions
 - How to provide a beacon?
 - How to discover devices?
 - How to react quickly to obstructions?
 - How to adapt the beam?
 - Do we need feedback?
 - Interference is likely to be low most of the times, but can I times, how to deal with it?

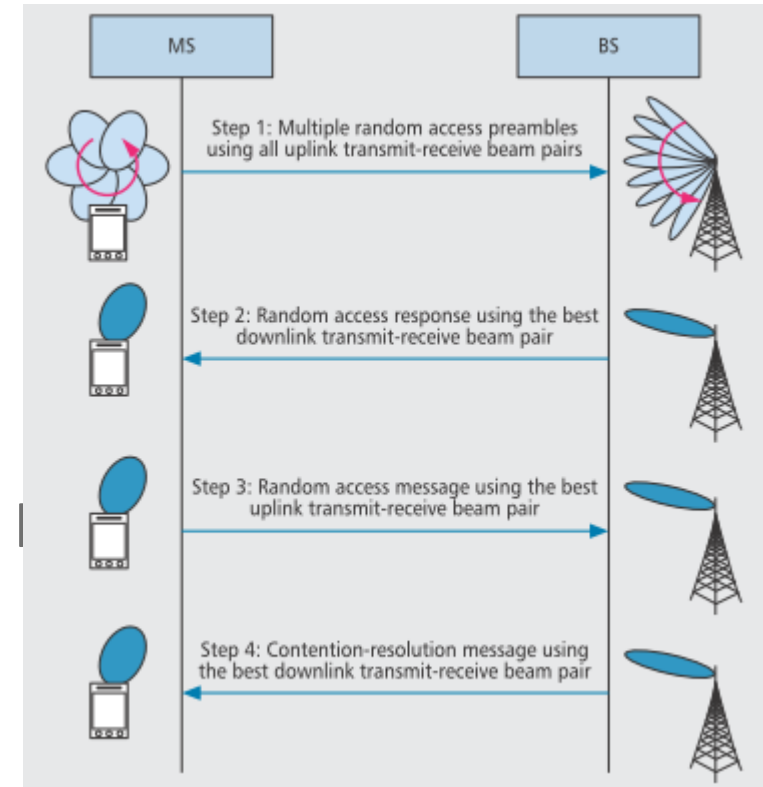

Jeong et al., *Random Access in Millimeter-Wave Beamforming Cellular Networks: Issues and Approaches*, IEEE Comm. Mag., 20015

mmWave – PHY challenges

- MIMO is used mostly for beamforming, hence spectral efficiency arises from
 - Very wide band signal (a few GHz)
 - ✓ How does channel/beamforming behave in this condition?
 - High SNIR \Rightarrow higher-order modulation schemes
 - ✓ But RF imperfections and ADC resolution tend to be significant at these frequencies
- Can equalization needs be relaxed on account of narrow beamwidths (particularly for not very wide bands)?
- Do we still need multicarrier?
 - challenging with low ADC resolution
 - PAPR

- Beyond mmWave
 - THz – submillimeter Waves
- High cost of hardware (for now)
- Possibly for very short links

VLC – VISIBLE LIGHT COMMUNICATION



VLC (Visible Light Communications)

- Visible Light Spectrum (between 430 and 790 THz) largely unexploited for data transmission
 - Cheap and widely available components (LEDs and photodetectors)
 - Line-of-Sight only, hence,
 - ✓ Short range,
 - ✓ but very little interference
 - may serve as a complement to radio networks, particularly in the downstream

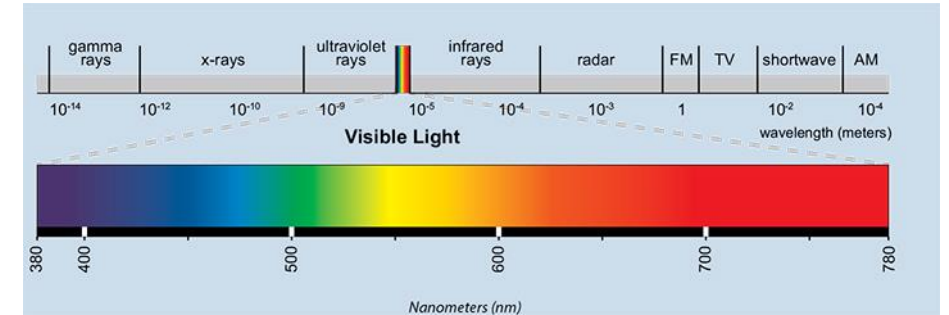

<http://www.eyelighting.com>

VLC

- Different applications
 - Home / office (indoors)
 - V2X
- Standards available
 - IEEE 802.15.7 (LiFi)
 - Up to 96Mbps in standard
 - ✓ But multi-Gbps rates in labs

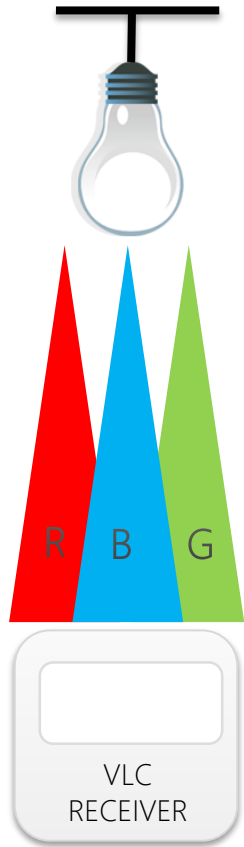
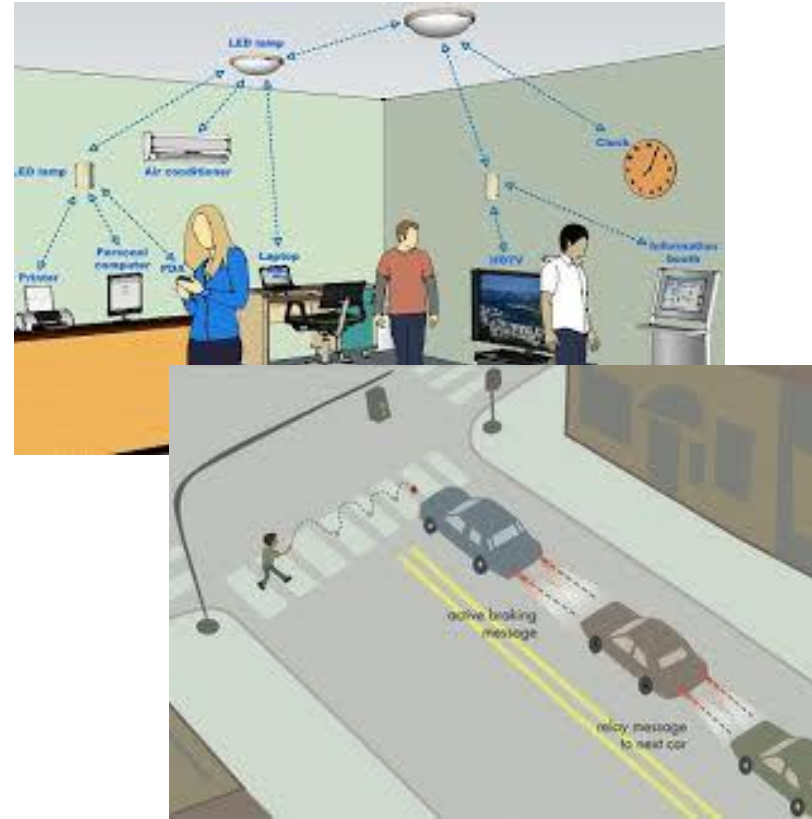

FSO (Free-Space Optical Links)

- Directional links can be created using lasers
- Can be a possible solution for wireless backhaul
- Challenges:
 - Tx/Rx modems must be aligned
 - Signal is attenuated by fog/heavy rain
 - Transmission is interrupted by physical obstructions (e.g., birds)



HARDWARE IMPLEMENTATION



Hardware Implementation

- 5G imposes tough requirements. Some of them are even contradictory.
- Let's revisit some challenging requirements for 5G

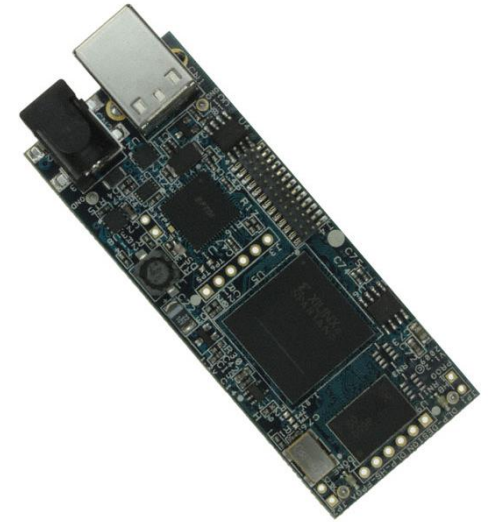
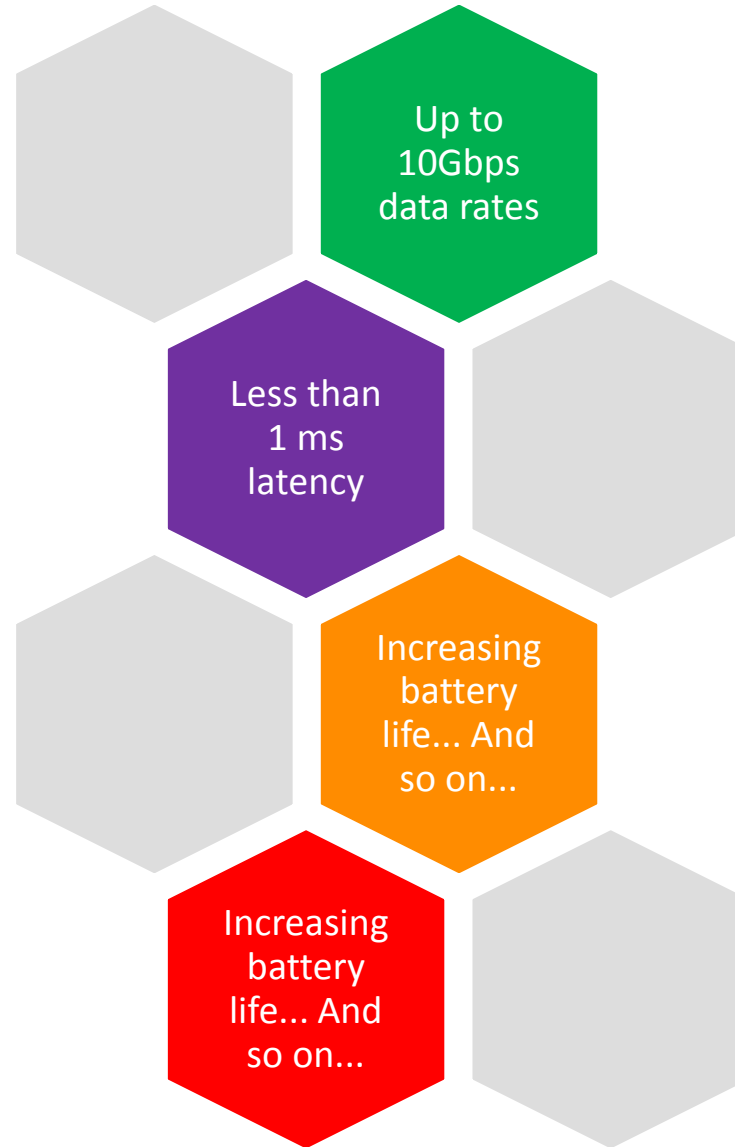

Hardware Implementation

- But what does this mean in terms of implementation?

New techniques in advanced waveform modulation, coding, multiple access and full-duplex radios.

Complex baseband algorithms must run on highly efficient processing architecture to cope with throughput and latency requirements

Use of mmWave frequencies and physically small antennas.

SDR technologies need to be integrated in 5G architectures to allow flexible use of spectrum and access technology

Flexible and cost-effective RF front-ends

Hardware Implementation

- In mobile communications the adoption of an advanced technology depends on the status of CPU, DSP, A/D Converters, RF, analog passive components like antennas and others...
- Hardware, Integrated Circuits (IC) and other components of the radio transceiver must evolve to meet those requirements



High speed digital processing systems

- DSPs
- FGPAs
- GPU

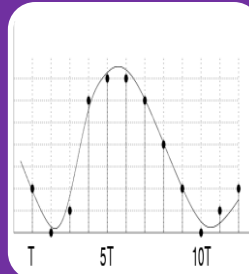

High Speed D/A Converters

- Suitable for Direct RF Sampling

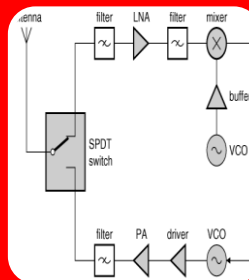

RF Front-End enhancements

- Low jitter, clock recovery, synchronization
- Wider operating ranges, multi-band

Hardware Implementation

- Semiconductor vendors are offering a huge number of processing platforms from highly specialized HW to general purpose applications
- Some times an optimal base-band algorithm is not realizable in real world because of implementation complexity or time complexity.
- So the key question is...

Hardware Implementation

- ...how to achieve high performance with low power consumption in a small form-factor?
 - **FPGA** technology evolved a lot and implementation has become easier with use of IP blocks. But they are still power hungry.
 - **DSPs** consumes less power and are easy to program, but processing speed is an issue for some algorithms and bit-wise computation
 - **GPU** has it's niche in image processing and are gaining attention on SDR design. Power consumption is an issue here also.

Hardware Implementation

- Base-band processing and algorithm execution. How fast are we going??
 - Highly specialized DSPs, FPGA other computing architectures are evolving quite fast in recent years.
- The good news is that Moore's Law is not that saturated

We can rely on Moore's Law so IC development will drive technical progress in 5G!

Increase in transistor count and transistor density. Some architectures support a high degree of parallelism

Microprocessor Transistor Counts 1971-2011 & Moore's Law

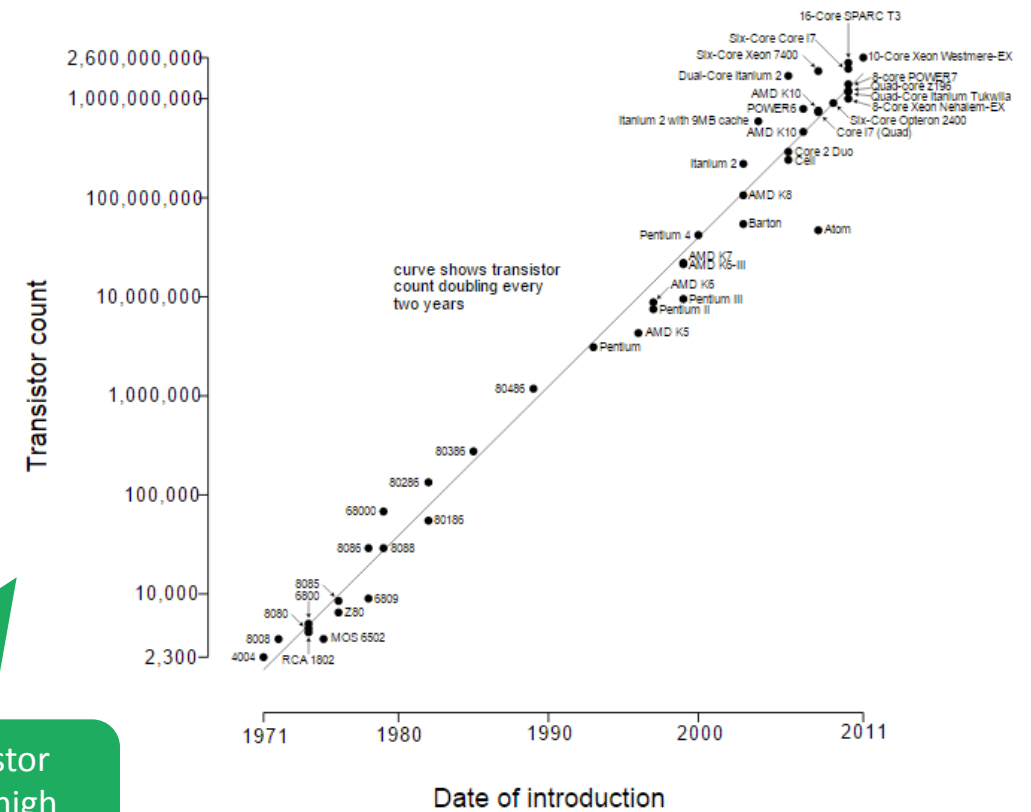

Hardware Implementation

There are some Massive Parallel Architectures out there that combine the power and programmability of DSPs with parallelization using a grid of hundreds of Processing Elements.

	5G
Bandwidth (MHz)	200
Subcarrier Spacing (kHz)	60
Symbol length (μ s)	16.67
FFT Size	2048
Effective Subcarriers	3200
Sampling Frequency (MHz)	245.76
CP duration (μ s)	1
Waveform	ZT-DS-OFDM

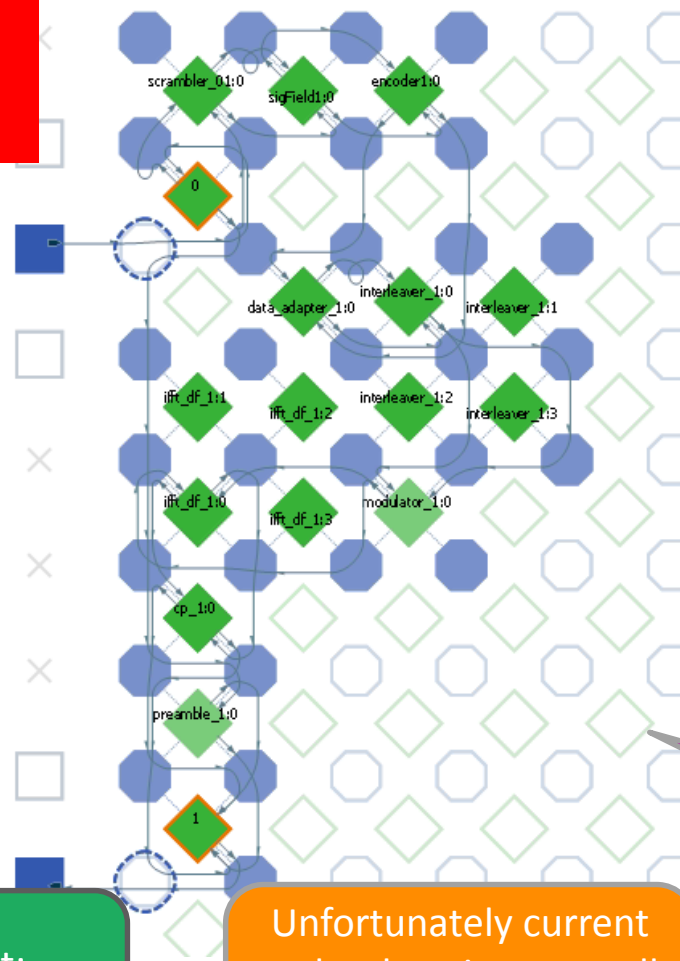

Example of a Network on Chip (NoC) processor with 10x10 PE grid.

This example shows a Tx chain NoC that achieves those processing constraints

Requirement:
~3 Mega MAC/s

Unfortunately current technology is not small enough for mobile or sensor equipment

Each diamond shape is a Processing Element

Hardware Implementation

- RF signal must be in digital form before processing. This is where DACs come into place.
- With higher bands the sampling rate of DACs must increase in magnitudes of order.

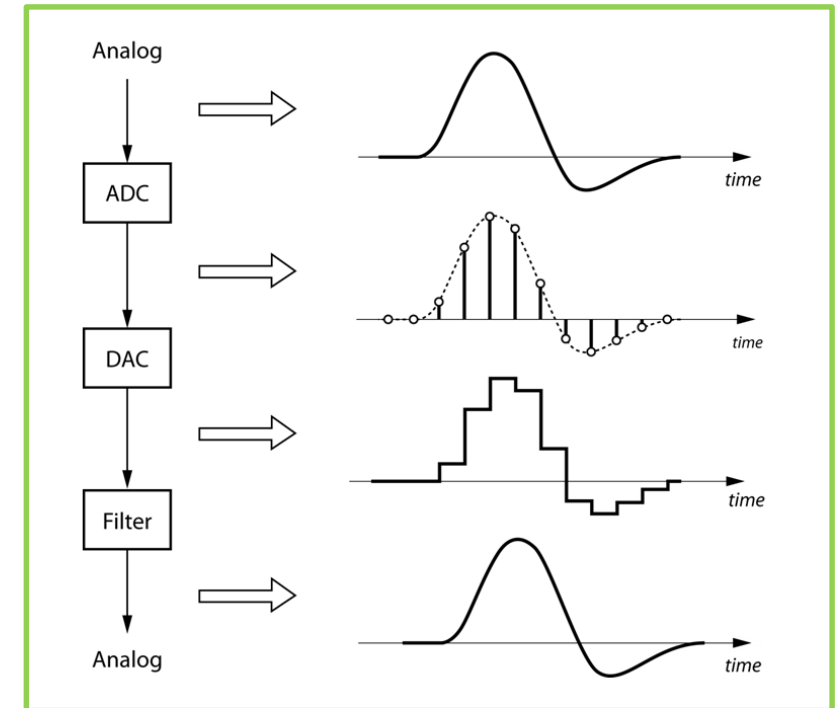

Hardware Implementation

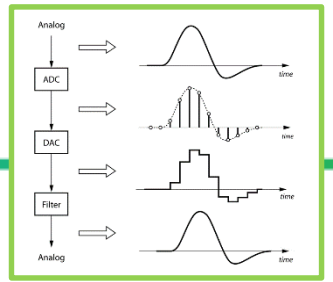

- Direct RF sampling is one of the development areas for 5G.
 - With direct RF sampling the RF signals are digitally generated and sent directly to DACs for transmission without up-conversion.
 - ✓ It implies lower overall system complexity and cost: don't need multiple stages of filtering, synthesizers and mixers – no image rejection.
 - ✓ Better flexibility in modulation schemes and bands
 - ✓ Simplification of the challenges associated with Carrier Aggregation...
- Some GSamples/s ADC are being offered (TI for example) but they're still expensive and power hungry for mobile devices application

Hardware Implementation

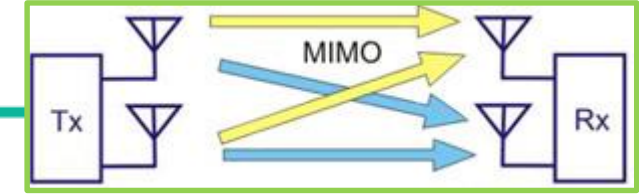

- Multi-antenna transceiver and massive MIMO are key technologies to achieve high throughputs in 5G
- A massive MIMO system requires important attributes like:
 - Accurate time and frequency synchronization
 - High throughput BUS to interconnect processing elements
 - High performance processing for PHY execution to meet real-time constraints and execute MIMO precoding extremely fast!
- The industry already presented some test-bed equipment for developing innovative solutions and waveforms for 5G. But they are far from being in a small form-factor suitable for mobile equipment.

Hardware Implementation

Large antenna systems
Cost and power of components
are high

Hybrid precoding: Analog phase
shifters controlled digitally.
Need lots of processing speed!

Dedicate a separate RF chain for
each antenna is costly and
requires a lot of power

Some MIMO processing
will be performed in
analog

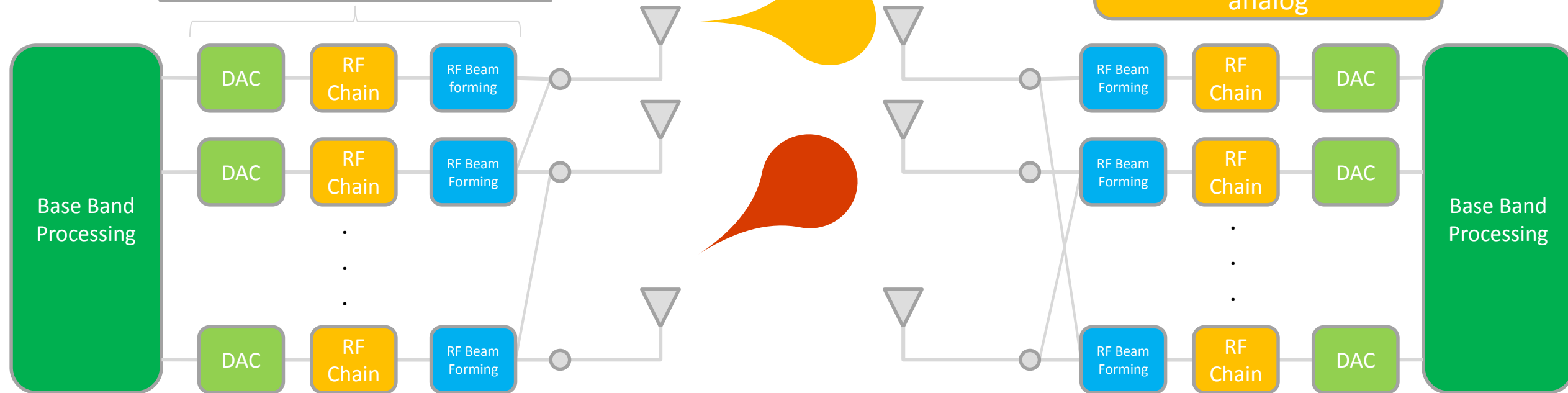

Hardware Implementation

- Other HW impairments...
 - For large BW Power Amplifier Non-linearity becomes an issue
 - In high frequencies, imperfections of oscillators are much more evident.
 - Fitting a large number of antennas in small equipment is challenging engineering problem.
 - Design of PCB with high frequency BUS is challenging.

Hardware Implementation

- Conclusions
 - 5G communication shows potential to offer orders of magnitude of capacity over current communication systems
 - However architectures and protocols must be redesigned to meet the tight requirements of 5G.
 - Integrated Circuit, system, algorithms and RF components must evolve to promote the technology necessary for 5G.

STANDARDIZATION



ITU – Workplan for IMT 2020

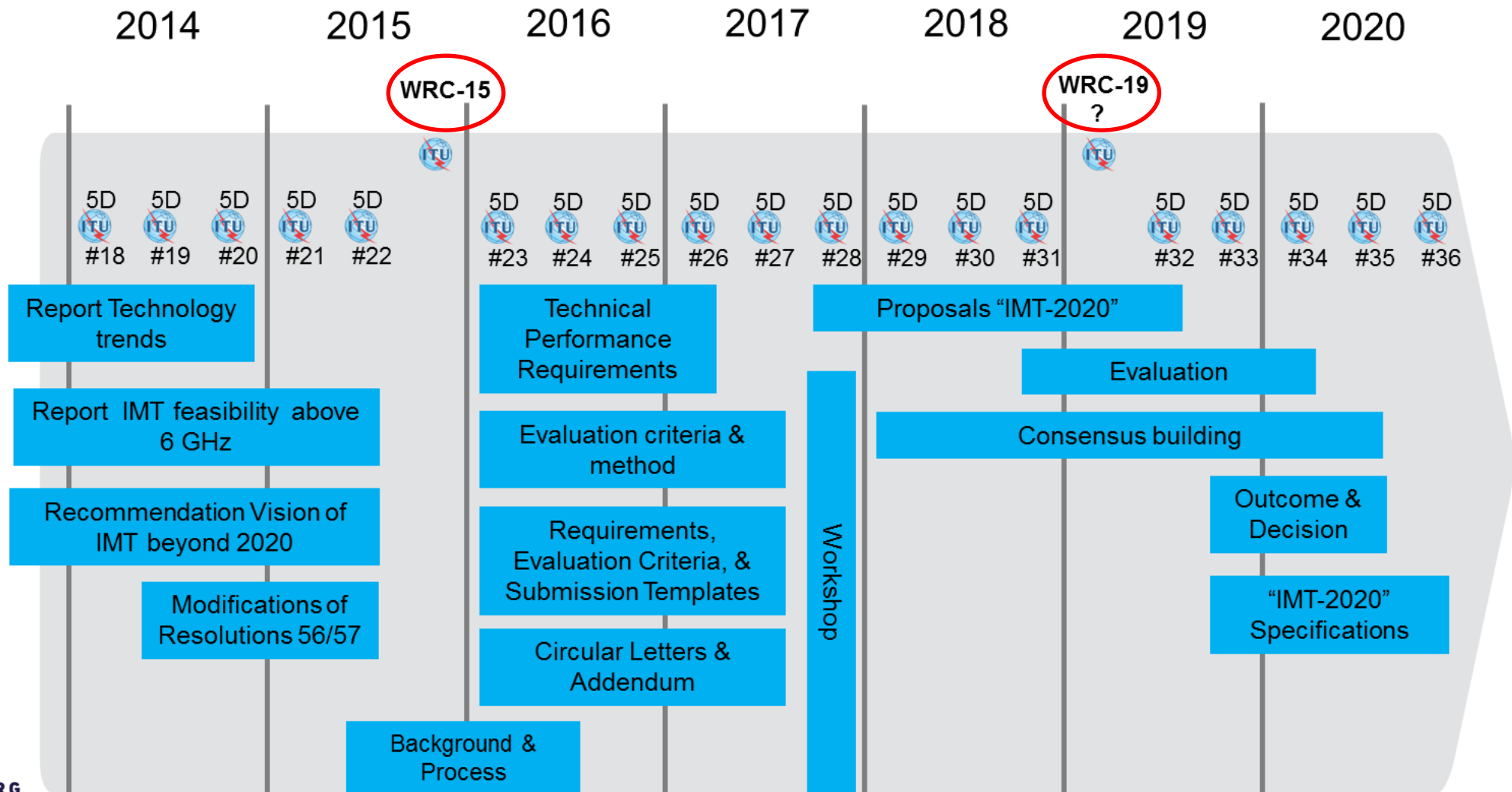

3GPP and 5G



The Mobile Broadband Standard

[About 3GPP](#)[Specifications Groups](#)[Specifications](#)[3GPP Calendar](#)[Technologies](#)[News & Events](#)

[Home](#) ▶ [News & Events](#) ▶ [3GPP News](#) ▶ [3GPP and the Broadband Forum Collaborate on Fixed/Mobile Convergence Standards](#)

Tentative 3GPP timeline for 5G

March 17, 2015

By Dino Flore, Chairman of 3GPP RAN and Balazs Bertenyi, Chairman of 3GPP SA

Last week, 3GPP endorsed a tentative timeline for the standardization of next generation cellular technology, also known as "5G" [1]. The tentative timeline is shown in the picture below. This article briefly summarizes some of the key milestones and how the work is expected to proceed in 3GPP working groups.



3GPP and 5G

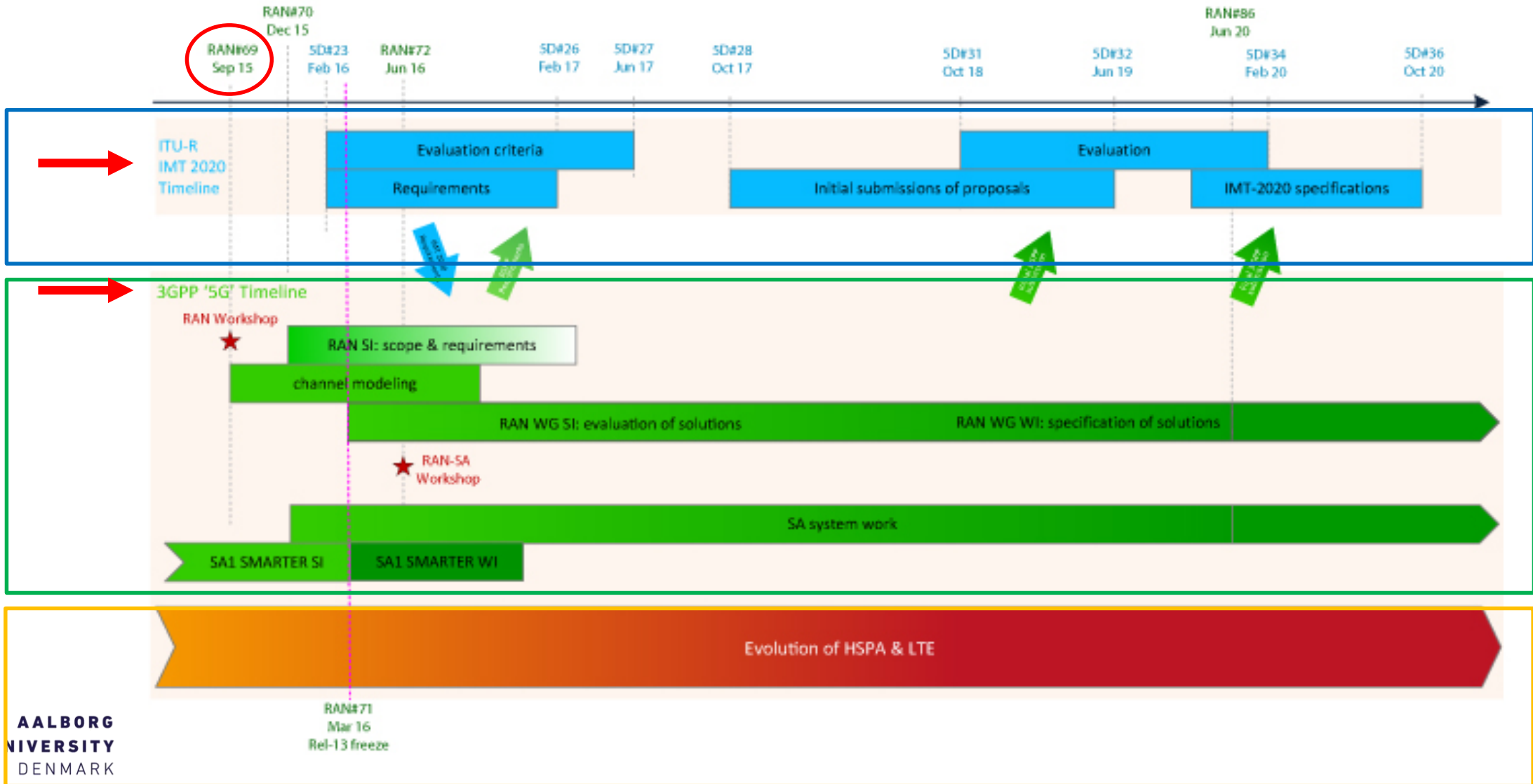

SUMMARY



Summary

- Requirements for new IoT and large-scale broadband wireless are very demanding
- 5G will not be just an evolution of 4G!
- A whole set of new Technologies are needed
 - Architectural changes
 - Communications theory challenges (modulation/coding/signal processing)
 - Novel Hardware
 - New spectrum

Summary

- It is not going to be an easy task (and profit margins tend to be low)
- Good News is
 - Plenty of research work to be done until 2020
 - hopefully jobs, research grants, start-up opportunities and fun ...





THANK YOU

andre.noll@indt.org

bruno.faria@indt.org

erika.almeida@indt.org.br

irl@es.aau.dk

rafael.amorim@indt.org.br

robson.d.vieira@indt.org.br